



ZIMMER BIOMET  
Your progress. Our promise.®



# The Tether™

Vertebral Body Tethering System

*Ahead of the Curve™*

Surgical Technique Guide



Federal (USA) law restricts this device to sale by or on the order of a physician. **R<sub>x</sub>**<sup>only</sup>

**Humanitarian Device**

Authorized by Federal law for use in the treatment of skeletally immature patients that require surgical treatment to obtain and maintain correction of progressive idiopathic scoliosis, with a major Cobb angle of 30 to 65 degrees whose osseous structure is dimensionally adequate to accommodate screw fixation, as determined by radiographic imaging. Patients should have failed bracing and/or be intolerant to brace wear. The effectiveness of this device for this use has not been demonstrated.

## TABLE OF CONTENTS

Important Information on The Tether System	4
System Overview	6
Instruments	8
Surgical Technique	10
Preoperative Planning	10
Patient Positioning	10
Pre-surgical Instrument Assembly	11
Surgical Approach	20
Anchor Insertion	21
Screw Preparation and Insertion	23
Placement and Tensioning of the Flexible PET Cord	27
– Option 1: Sequential (or segmental) Tensioning	28
– Option 2: Multi-segment Tensioning	37
Closure	47
Revision/Removal	47
Special Cleaning Instructions for Tensioner	47
Kit Contents	48

*Zimmer Biomet Spine does not practice medicine. This technique was developed in conjunction with health care professionals. This document is intended for surgeons and is not intended for laypersons. Each surgeon should exercise his or her own independent judgment in the diagnosis and treatment of an individual patient, and this information does not purport to replace the comprehensive training surgeons have received. As with all surgical procedures, the technique used in each case will depend on the surgeon's medical judgment as the best treatment for each patient. Results will vary based on health, weight, activity and other variables. Not all patients are candidates for this product and/or procedure.*

## IMPORTANT INFORMATION ON THE TETHER™ – VERTEBRAL BODY TETHERING SYSTEM

### DEVICE DESCRIPTION

The Tether™ – Vertebral Body Tethering System is a non-fusion spinal device intended for treatment of idiopathic scoliosis. Anchors and vertebral body screws are placed laterally from a thoracoscopic or thoracotomy approach into the vertebral body on the convex side of a spinal deformity. A SULENE® polyethylene terephthalate (PET) tensioning cord is secured to the vertebral body screws with set screws to connect the levels of the construct. The device provides a lateral tension band across the convex side of the spine that, on insertion and tensioning, partially corrects the curvature, and subsequently can arrest or correct the deformity through modulation of remaining spinal growth. In addition, the subject system includes instrumentation for insertion, manipulation, and removal of the implants.

### MATERIALS

The Tether™ - Vertebral Body Tethering System is manufactured from:

- Anchors: Ti 6Al-4V ELI titanium alloy per ASTM F136
- Set Screws: Ti 6Al-4V ELI titanium alloy per ASTM F136
- Bone Screws: Ti 6Al-7Nb titanium alloy per ISO 5832-11 with an hydroxyapatite coating per ISO 13779-2
- Cord: Sulene® PET (polyethylene-terephthalate)
- Instruments and Cases: Generally comprised of aluminum, stainless steel, titanium alloy, and/or polymeric materials

### INDICATIONS FOR USE

The Tether™ - Vertebral Body Tethering System is indicated for skeletally immature patients that require surgical treatment to obtain and maintain correction of progressive idiopathic scoliosis, with a major Cobb angle of 30 to 65 degrees whose osseous structure is dimensionally adequate to accommodate screw fixation, as determined by radiographic imaging. Patients should have failed bracing and/or be intolerant to brace wear.

### CONTRAINDICATIONS

The Tether™ - Vertebral Body Tethering System should not be implanted in patients with the following conditions:

- Presence of any systemic infection, local infection, or skin compromise at the surgical site;
- Prior spinal surgery at the level(s) to be treated;
- Known poor bone quality defined as a T-score -1.5 or less;
- Skeletal maturity;
- Any other medical or surgical condition which would preclude the potential benefit of spinal surgery, such as coagulation disorders, allergies to the implant materials, and patients unwillingness or inability to cooperate with post-operative care instructions.

### SUMMARY OF CLINICAL EXPERIENCE

For a summary of clinical experience, please reference the system's Instructions for Use (IFU).

### PREOPERATIVE PROCEDURE

The surgeon is responsible for being familiar with the indications, contraindications, system/procedure risks, and surgical technique to ensure proper treatment, patient selection, and postoperative care when using The Tether™ - Vertebral Body Tethering System. The patient must be an acceptable surgical risk, and appropriate for vertebral body tethering based on consideration of various factors such as preoperative Cobb angle, curve flexibility, curve type(s), curve location(s), skeletal maturity, and anticipated growth, among others. Examination and evaluation of the individual patient anatomy is necessary to plan the appropriate surgical procedure and technique. Due to smaller vertebral body size and variable venous anatomy, caution should be observed if extending instrumentation proximal to T5.

Zimmer Biomet Spine does not specify the maximum number of times a re-usable instrument may be re-used. The useful life of these instruments is highly dependent on a number of factors including the frequency and manner in which they are used and the handling they experience in between uses. Inspection and, where appropriate, functional testing prior to instrument use is the best way to determine whether or not an individual device should be used. Review and inspect all instrumentation and implants prior to use. Replace or add any needed components for the planned surgery.

Use of automated cleaning processes without supplemental manual cleaning may not result in adequate cleaning of instruments. Proper handling, decontamination (including pre-rinsing, washing, rinsing and sterilization), storage and utilization are important for the long and useful life of all surgical instruments. Even with correct use, care and maintenance, instruments should not be expected to last indefinitely. This is especially true for cutting instruments (e.g., bone awls/drills) and driving instruments (e.g., drivers). These items are often subjected to high loads and/or impact forces. Under such conditions, breakage can occur, particularly when the item is corroded, damaged, nicked or scratched.

### OPERATIVE PROCEDURE

For surgical placement of The Tether™ - Vertebral Body Tethering System, patients are positioned in the lateral decubitus position with the convex side of the curve to be instrumented facing upwards. As most idiopathic thoracic curves are convex towards the right side, a left lateral decubitus position will be the most common position utilized for instrumentation of thoracic curves. For recommended surgical site preparation, positioning, and technique details, please see the Surgical Technique Guide. For thoracoscopic surgery, standard anesthesia protocol should be observed. However, it is recommended to use a single lung ventilation technique such as a double-lumen endotracheal tube to aid surgical exposure if necessary. Anchor use is recommended at all levels. Consideration should be given to the osseous structure at each level to determine if both a bone screw and anchor are needed to adequately support the construct and anticipated loads. Please refer to the Surgical Technique Guide if implant removal is required (including revision). Close wound(s) and apply wound dressing using standard techniques.

### POSTOPERATIVE CARE

It is critical that patients follow all postoperative instructions provided by care providers including recommendations regarding medications, home care, surgical wound dressings and activity limitations. The patient must be warned to avoid falls or sudden jolts. Failure to follow postoperative instructions could lead to impaired wound healing, injury to neurologic structures or failure to achieve desired curve correction.

Optional protective bracing may be used for up to six months after surgery depending on patient factors such as bone quality and activity levels. Bracing may provide additional support for patients who are overcorrecting or have a suspected or confirmed cord break. Use of The Tether does not preclude the need to brace compensatory curves.

### WARNINGS

- Do not rotate the screw counterclockwise after insertion. This will reduce stability of the implant in the vertebral body.
- New or increasing coronal angulation between consecutive screws as seen on radiographs may indicate tether breakage. Tether breakage may be associated with loss of correction, overcorrection or may have no clinical significance.
- Never use titanium alloy(s) with stainless steel in the same implant construct; otherwise, galvanic corrosion may occur.
- When tensioning the construct, special consideration should be given to patients with considerable growth remaining (e.g. open triradiate cartilage), lower magnitude Cobb angles, and/or high flexibility as excessive tension may increase the risk of overcorrection.
- The Tether™ - Vertebral Body Tethering System must not be used with vertebral components or instruments from other manufacturers. Specialized instruments are designed for Zimmer Biomet Spine implant systems to aid in proper implantation. The use of instruments or implant components from other systems can result in inaccurate fit, incorrect sizing, excessive wear and device failure.
- Surgical instruments are subject to wear with normal usage. Instruments with cutting functions or points may become dull with normal use and no longer perform as intended. Instruments that have experienced extensive use are susceptible to fracture.
- Do not modify instruments. Do not notch, bend, or reshape instruments. Notches, scratches or other damage and/or wear in the instrument occurring during surgery may contribute to breakage. Do not use an instrument that has become bent from its original shape as this will affect the performance of the instrument. Bent instruments should be disposed of by a Zimmer Biomet Spine representative or according to hospital procedures.
- The use of an instrument for tasks other than those for which they are indicated may result in damaged or broken instruments.
- Proper handling of the instruments and implants before and during the operation is crucial. Do not apply excessive force; misuse can damage instruments or implants.

### PRECAUTIONS

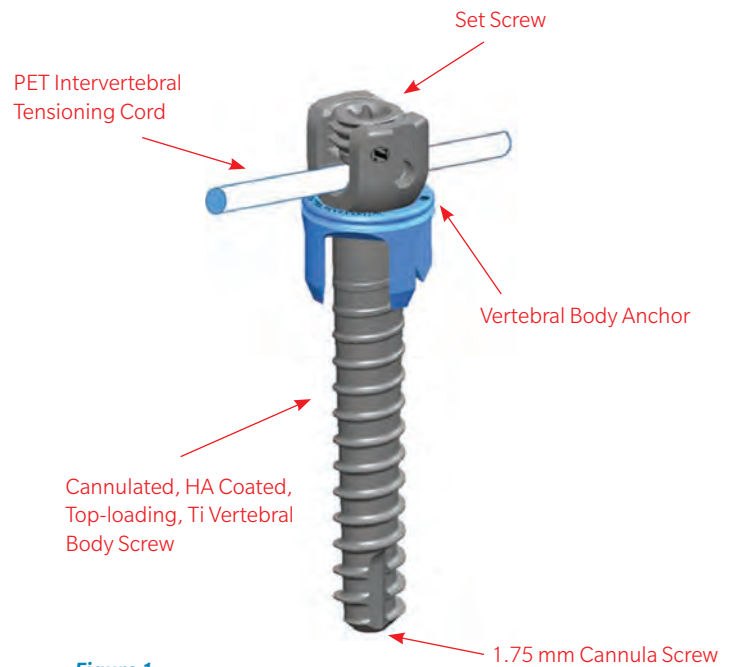
- Due to smaller vertebral body size and variable vascular anatomy, caution should be observed if extending instrumentation proximal to T5.
- Care should be taken when using instruments over a guidewire to avoid unintentional advancement of the guidewire which could result in damage to vessels, spinal cord, or lungs.
- Extreme caution must be taken to avoid damage to vessels, spinal cord, or lungs during placement of instruments and implants.
- The Tether™ - Vertebral Body Tethering System is intended to be used by surgeons specialized in spinal surgery with thorough knowledge of vertebral anatomy, regional vertebral morphology, and biomechanical principles of the spine. The surgical procedure is technically demanding and presents a risk of serious injury to the patient. It is advised that the surgeon also be thoroughly familiar with the surgical techniques, equipment, and instruments related to the use of the device. The surgical technique guide may be obtained by contacting Zimmer Biomet Spine Customer Service (contact information is provided below).
- Risks associated with spine surgery, neurosurgery, general surgery, and the use of general anesthesia should be explained to the patient prior to surgery. It is recommended that the advantages and disadvantages of using The Tether™ - Vertebral Body Tethering System, as well as alternative treatment methods, are explained to the patient.
- The cord implant is made up of three-segments: The Introduction Zone, the Working Zone, and the Functional Zone. Only the Functional Zone may be implanted into the patient.
- Correct selection and placement of the implants is critical. Implant selection must be based upon the levels to be treated as well as the patient's weight and height.
- Perform a careful preoperative review to be sure that all necessary implant components are available and that the instrument set is complete and in working order prior to initiating surgery.
- Before use, inspect all instrumentation for possible damage, wear, or non-function. Damaged or defective instruments should not be used or processed. Contact your local Zimmer Biomet Spine representative or distributor for repair or replacement.
- Do not reuse single-use devices such as implants. While a single-use device may appear undamaged, previous stress may have created imperfections that would reduce the service life of the single-use device. Do not treat patients with single-use devices that have been in contact with a different patient.
- All trial, packaging, and instrument components must be removed prior to closing the surgical site.
- Unless otherwise indicated, instruments are supplied NON-STERILE and must be thoroughly cleaned and sterilized prior to use. Instruments that are not clean may not be effectively sterilized.
- Automated cleaning using a washer/disinfector alone may not be effective for complex orthopaedic instruments with lumens, cannulations, blind holes, mated surfaces and other features.
- Do not clean soiled instruments while in polymer or metal trays.

## SYSTEM OVERVIEW

### Implants

The Tether™ – Vertebral Body Tethering System is comprised of four main components—a titanium alloy vertebral body anchor; a cannulated, hydroxyapatite-coated, vertebral body bone screw; a polyethylene-terephthalate (PET) intervertebral tensioning cord; and a titanium set screw (Figure 1).

The Tether™ – Vertebral Body Tethering System is intended to treat skeletally immature patients that require surgical treatment to obtain and maintain correction of progressive idiopathic scoliosis.



**Figure 1**  
Implant components

### Implant Components

#### Vertebral Body Anchor

The vertebral body anchors accommodate each vertebral body bone screw diameter offered in The Tether™ – Vertebral Body Tethering System. These anchors feature three straight tines designed to add greater stability to the construct (Figure 2).

#### Vertebral Body Bone Screw

The vertebral body bone screw is available in 5.5 mm, 6.0 mm, 6.5 mm, and 7.0 mm diameters and includes lengths from 20 mm to 50 mm, in 2.5 mm increments. The screw is made from titanium alloy and features a top-loading design, for ease of cord insertion. The vertebral body bone screws also include a 1.75 mm cannula screw, for use with an optional 1.45 mm diameter guidewire. The vertebral body bone screw features an outer layer of hydroxyapatite (Figure 3).



**Figure 2**  
Vertebral body anchor



**Figure 3**  
Vertebral body bone screw

### Cord

The flexible polyethylene-terephthalate (PET) intervertebral tensioning cord is used in conjunction with the other implants in the system, to apply compressive forces across the convexity of a scoliotic curve.

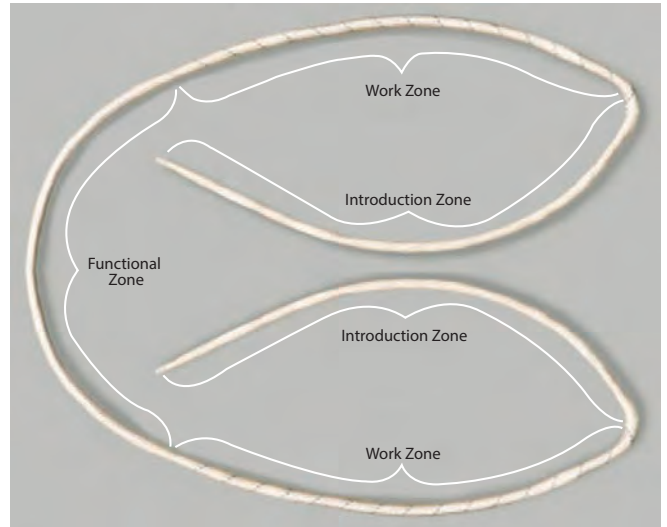
The cord features a central functional zone, two peripheral working zones, and introduction zones on the ends of the cord. The introduction zone is designed to help start threading the cord to the extension spring tube and the tensioner. The working zone is intended for use in capturing, manipulating, and tensioning the overall cord. The central functional zone is placed within the tulip heads of the vertebral body bone screw and is part of the final implant construct. Do not use the introduction or working zone sections of the cord in the final construct (Figure 4).

### Set Screw

The titanium alloy set screw features a customized T20 hexalobe interface and a reverse buttress thread form (Figure 5). It is used to secure the cord in the vertebral body screw saddle of the tulip head.

**Caution:** Only use the torque-limiting T-handle with the set screw driver to introduce and tighten the set screws.

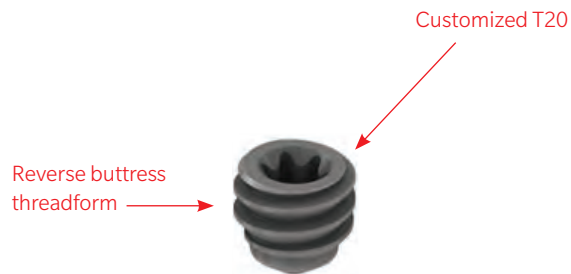
**Caution:** Repetitive adjustment of the set screw is not recommended, nor is adjustment of the set screw after final tightening has been performed.



PET cord



**Figure 4**  
Final construct



**Figure 5**  
Set screw

## INSTRUMENTS

### All-Through-One (ATO) Instrument:

Anchor Inserter Inner Sleeve



Anchor Inserter Outer Sleeve and Handle



Awl



Awl Long



Anchor Inserter 90° Handle



Ratcheting Handle, Palm (x1)



**Note:** When a K-wire is used, the Ratcheting Handle, Palm (230H5503) should be used. The Ratcheting Handle (230H5502) should NOT be used as the K-wire may not extend through the end of the handle.

### Taps (Cannulated)



5.0 mm

5.5 mm

6.0 mm

6.5 mm

7.0 mm

### Taps (Non-Cannulated)



4.5 mm

5.0 mm

5.5 mm

6.0 mm

6.5 mm

7.0 mm

### Sounding Probes (x2)



### Screwdrivers (x2)



### Ratcheting Handle (x1)

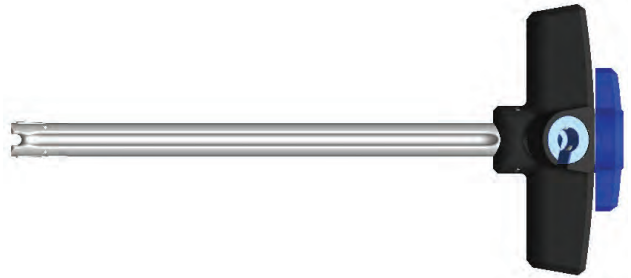




Set Screw driver (x2)



Counter-Tensioner (x2)



Cord Alignment Rod (x2)



Torque-limiting Handle (50 in-lb) (x2)



Cord Tensioner (x2)



Extension Spring Tube Short



Extension Spring Tube Long



Fine Adjustment Knob



## SURGICAL TECHNIQUE

**Preoperative planning** – It is highly recommended that surgeons take ample opportunity to plan their approach, including implant dimensions and level selection, using the most recent and best quality imaging studies they have available. Accuracy of implant placement and selection is highly dependent upon this preoperative planning process. It is also imperative that vertebral body screw dimensions be planned prior to surgery.

The patient must be an acceptable surgical risk and appropriate for vertebral body tethering based on consideration factors such as preoperative Cobb angle, curve flexibility, curve type(s), curve location(s), skeletal maturity, and anticipated growth, among others.

Constructs should extend from the cephalad vertebra to the caudal vertebra of the curve to be surgically corrected. However, due to smaller vertebral body size and variable venous anatomy, caution should be observed if extending instrumentation proximal to T5.

## PATIENT POSITIONING

- Place the patient in a lateral decubitus position, with the convex side of the curve to be instrumented facing upwards. As most idiopathic thoracic curves are convex towards the right side, a left lateral decubitus position will be the most common position utilized for instrumentation of thoracic curves.
- It is important to securely maintain the patient in a fully lateral position on a radiolucent OR table at all times. This may be achieved with the use of lateral positioning accessories or taping the patient directly to the table.

It is essential to have thoracotomy instruments in the OR, during a vertebral body tethering procedure. This is done as a precautionary measure, should an unexpected need for a thoracotomy arise.

Both thoracoscopic and thoracotomy techniques are accepted access techniques for vertebral body tethering surgery. For thoracoscopic surgery, a standard anesthesia protocol should be observed. However, it is recommended to use a single lung ventilation technique such as a double-lumen endotracheal tube to aid surgical exposure.

## PRE-SURGICAL INSTRUMENT ASSEMBLY

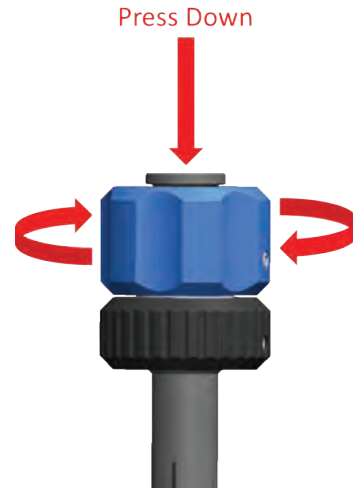
The All-Through-One (ATO) instrument is intended to provide the surgeon with the ability to implant the vertebral body anchor, prepare the site and insert the vertebral body bone screw, through a single cannulated instrument. This allows for more precise, deliberate, and consistent implant placement than freehand insertion using separate instruments.



**Figure 6**  
ATO assembly



**Figure 7**  
ATO sleeve alignment



**Figure 8**  
ATO sleeve engagement

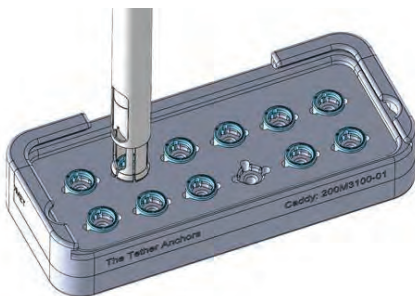
## ALL-THROUGH-ONE (ATO) AND AWL ASSEMBLY

- Insert ATO inner sleeve into the ATO outer sleeve (Figure 6).
- When these instruments are properly aligned, the witness mark on the outer sleeve shaft will be aligned with the witness mark on the inner sleeve, when observed through the alignment window (Figure 7).
- Once properly aligned, press on the proximal end of the ATO inner sleeve and simultaneously rotate the blue collar on the ATO outer sleeve in a counter-clockwise fashion (Figure 8). When done properly, the inner sleeve will be captured by the outer sleeve and the inner sleeve will begin to progress forward.

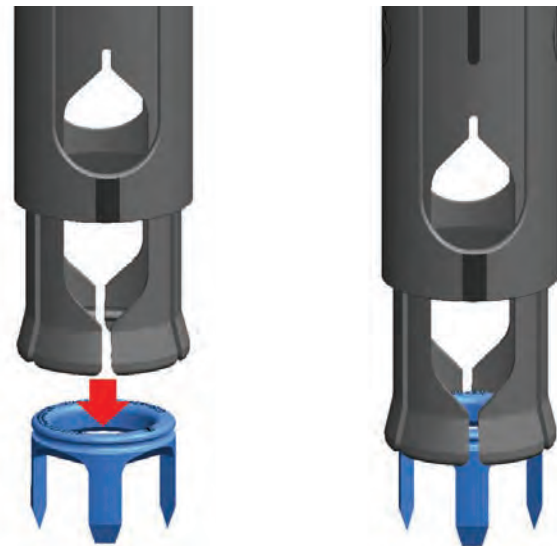
## PRE-SURGICAL INSTRUMENT ASSEMBLY (continued)



**Figure 9**  
ATO deployment



**Figure 10**  
Capture anchor in caddy



**Figure 11**  
Initial capture of anchor

## ALL-THROUGH-ONE (ATO) AND AWL ASSEMBLY (continued)

- Once the ATO inner and outer sleeves are provisionally assembled, turn the ATO's blue collar counter-clockwise until the distal end of the inner sleeve is fully deployed (Figure 9). When the distal end of the ATO's inner sleeve is fully deployed, it is ready to accept and provisionally capture the anchor implant.
- Remove the anchor implant caddy lid and press the distal end of the ATO over the anchor implant, while the implant remains seated in the caddy (Figure 10).
- Press downward until the end of the ATO captures and retains the anchor. An audible and tactile response should be observed when the distal end of the ATO properly captures the anchor (Figure 11).

**Figure 12**

*Anchor retraction and retention*

**Figure 13**

*Anchor fully captured, and sleeve fully retracted*

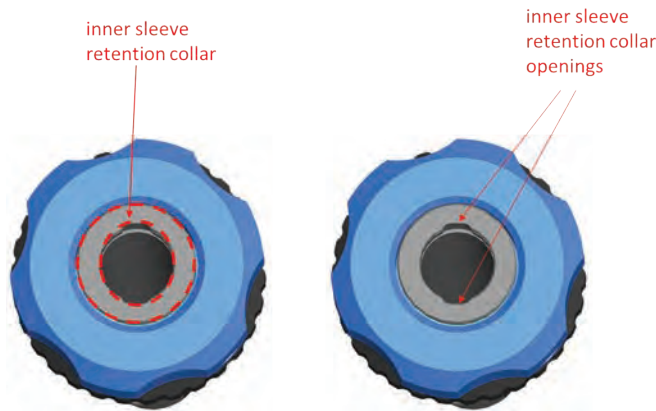
- Once the anchor is provisionally captured, rotate the blue collar of the ATO in a clockwise fashion—this will retract the distal end of the inner sleeve and fully secure the anchor to the ATO instrument (Figures 12 and 13). Do not force the ATO's blue dial.

There are two awls available in the system—a long awl with a sharp tip that measures 27 mm in length, and a shorter version with a tip that measures 17 mm in length. Both awls feature two retention posts on the proximal ends of each instrument and are found just beyond the strike pad/dial. Prior to using the long awl, the surgeon should be sure to thoroughly assess the size of the vertebral body to ensure that it is adequate to accommodate the longer length of this instrument's tip.

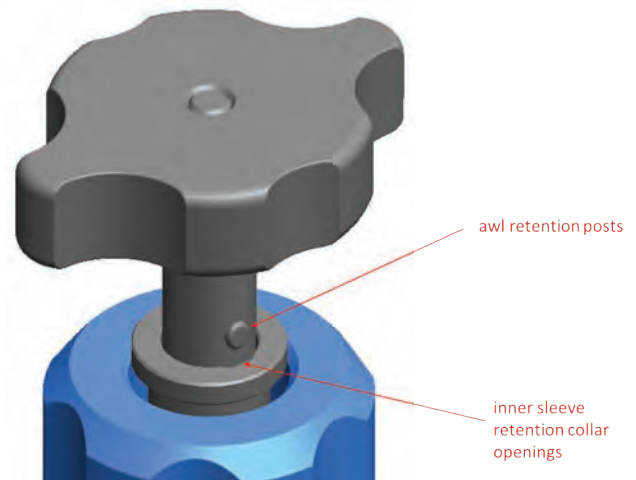
## PRE-SURGICAL INSTRUMENT ASSEMBLY (continued)



**Figure 14**  
Short awl



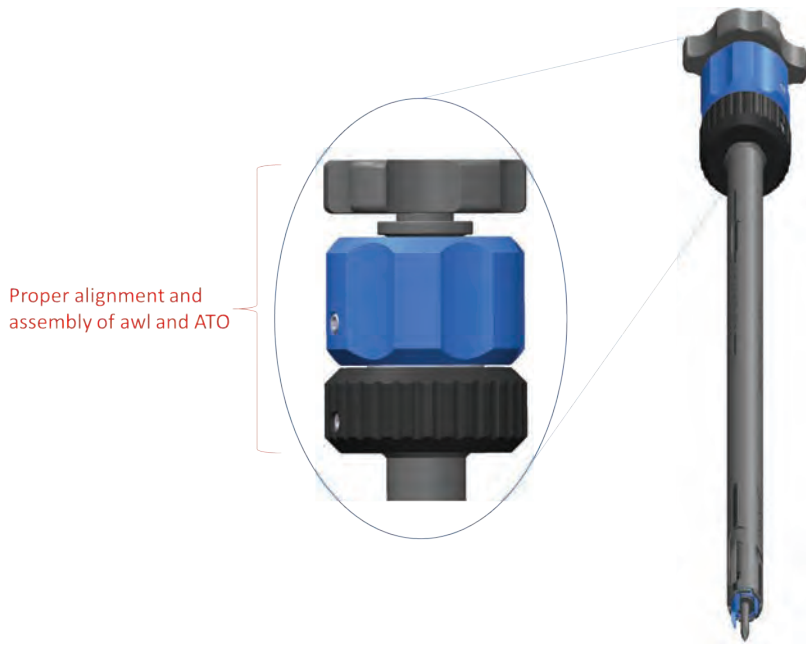
**Figure 15**  
Inner sleeve retention collar



**Figure 16**  
ATO and awl assembly

## ALL-THROUGH-ONE (ATO) AND AWL ASSEMBLY (continued)

- The retention posts are designed to interface with the retention collar of the ATO's inner sleeve (Figure 14).
- The retention collar features an oblong opening that will accommodate the retention posts when properly aligned (Figure 15).
- Insert the distal tip of the selected awl into the proximal cannula of the ATO instrument. If the strike pad/dial of the awl does not come to rest immediately next to the blue dial of the ATO, do not attempt to force the awl into place. The retention posts of the awl need to be properly aligned with the oblong opening of the ATO retention collar (Figure 16). Hold both instruments upright and rotate the strike pad/dial until the awl falls into place.



**Figure 17**

*Complete ATO, anchor, and awl assembly*

- 
- The ATO is now properly assembled with the awl and anchor implant and is ready for insertion (Figure 17).

## PRE-SURGICAL INSTRUMENT ASSEMBLY (*continued*)



**Figure 18**  
Tap and ratcheting handle assembly

### RATCHETING HANDLE WITH TAP

- After selecting the appropriate tap, insert its ¼" square proximal end into the distal recess of the ratcheting handle until it is captured. If the tap does not fully seat, rotate the shaft of the tap slightly during insertion. While still holding the ratcheting handle, tug on the tap to ensure that it is properly secured (Figure 18).

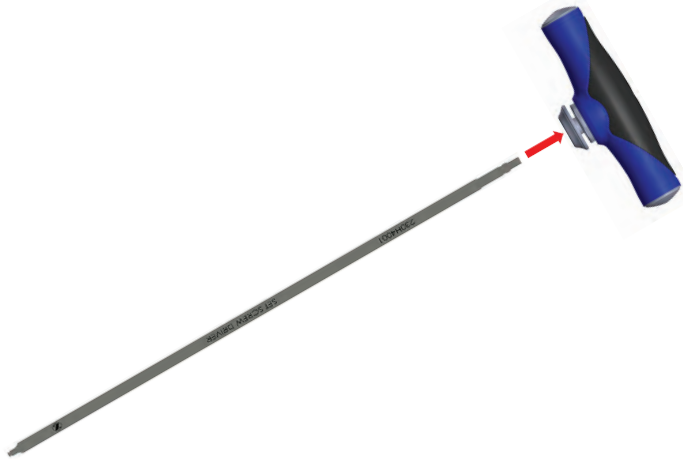


**Figure 19**  
Screwdriver and ratcheting handle assembly

### RATCHETING HANDLE WITH SCREWDRIVER

- Insert the ¼" proximal end of the screwdriver into the distal recess of the ratcheting handle until it is captured. If the screwdriver does not fully seat, rotate the shaft of the screwdriver slightly during insertion. While still holding the ratcheting handle, tug on the screwdriver to ensure that it is properly secured (Figure 19).



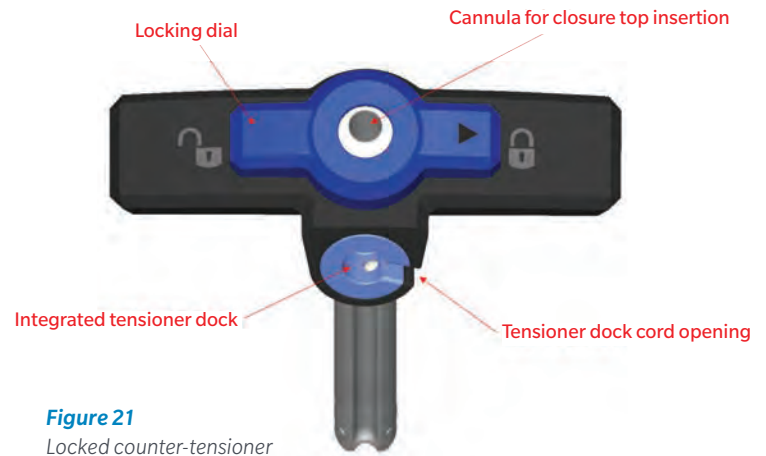


**Figure 20**  
Set screw driver and torque-limiting T-handle assembly

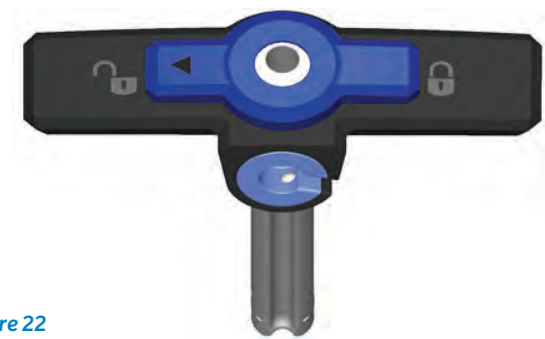
## TORQUE-LIMITING T-HANDLE WITH T20 SET SCREW DRIVER

- Insert the proximal end of the T20 set screw driver into the distal recess of the T-handle. Simply insert the set screw driver until it is captured by the T-handle. If the set screw driver will not fully seat, rotate the shaft of the set screw driver during insertion. While still holding the T-handle, tug on the set screw driver to ensure that it is properly secured (Figure 20).

**Note:** The torque-limiting T-handle is intended for return to Zimmer Biomet Spine for recalibration after 6 months or 150 autoclave cycles.



**Figure 21**  
Locked counter-tensioner



**Figure 22**  
Unlocked counter-tensioner

## COUNTER-TENSIONER

- The counter-tensioner is used to capture an implanted screw and assist with the cord tensioning and capture processes. The counter-tensioner features a cannula for introducing a set screw to the vertebral body bone screw, to secure the cord (Figure 21).
- Before attempting to attach the counter-tensioner to a screw implant, ensure that the locking dial on the T-handle of the counter-tensioner is in the unlocked position (Figure 22).
- The cord may be tensioned using the integrated tensioning port on the counter-tensioner's handle, or the counter-tensioner may be used in conjunction with the extension spring tube.

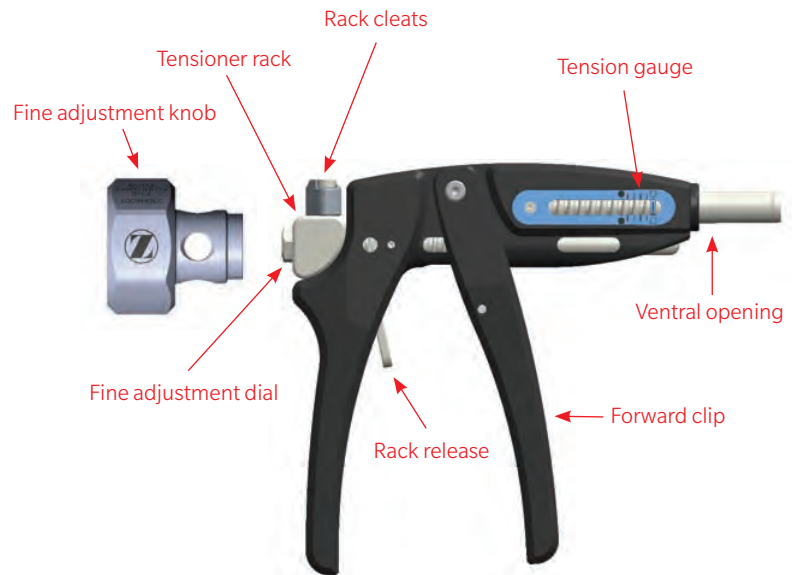
## PRE-SURGICAL INSTRUMENT ASSEMBLY (*continued*)



**Figure 23**  
Extension spring tube

### EXTENSION SPRING TUBE, LONG

- The extension spring tube eliminates the need to feed the cord through a port and into the dock of the counter-tensioner to tension the construct. The extension spring tube is typically inserted through the most caudal 15 mm port. Never tension the cord through the extension spring tube without the distal end of the tube first resting against the most caudal counter-tensioner (Figure 23).



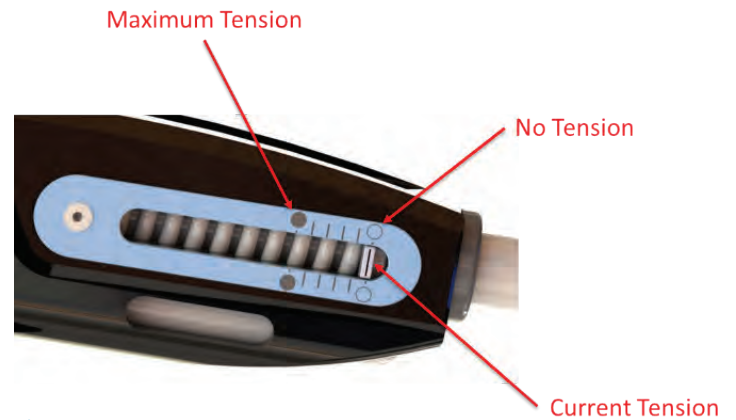
**Figure 24**  
Tensioner

### TENSIONER

- The tensioner is used to tension the cord along the implant construct. The tensioner can either be used in conjunction with the extension spring tube and a counter-tensioner, or with only a counter-tensioner. The tensioner features a ventral opening through which the cord is passed (Figure 24).



**Figure 25**  
Tensioner rack and cleat capture of cord



**Figure 26**  
Tension gauge

- Once the cord exits the body of the tensioner it is placed into the cleats of the tensioner's rack (Figure 25). This will secure the cord in place so that it may be tensioned.
- Tensioning is performed by squeezing the forward grip of the tensioner. If preferred, the surgeon may utilize the fine adjustment knob to add or reduce tension in a more precise manner than squeezing the grip of the tensioner. Place the fine adjustment knob on the back of the tensioner's rack and rotate clockwise for additional tension and counter-clockwise to reduce tension.
- The tensioner features a gauge that indicates the achieved proximal tension, but is not a direct indicator of tension across the implant construct (Figure 26). Tension on the cord at the implant construct will vary depending on whether the extension spring tube, or the counter-tensioner is being utilized to tension. The extension spring tube applies greater tension. Do not exceed the maximum tension marker when tensioning the cord.
- It is recommended to use the fine adjustment knob, to relieve tension along the cord, before pressing the silver tensioner release. This will help prevent the tensioner rack from rebounding as the release is depressed and the cord is relieved of tension.

## SURGICAL APPROACH

### NON-SCREW DELIVERY INSTRUMENTATION PORTS

#### Screw Insertion Portal Preparation

Once the patient is properly positioned, identification of the entry portals for screw insertion should be done prior to preparation and draping. This is done to ensure proper visualization of each vertebral body to be instrumented. The entry points for screw insertion can be estimated from posterior-anterior and lateral fluoroscopy images, taking care to align the fluoroscopy between each image, so that a perfectly orthogonal view of the vertebra is obtained. The portal sites for screw insertion are typically in the posterior-axillary line.



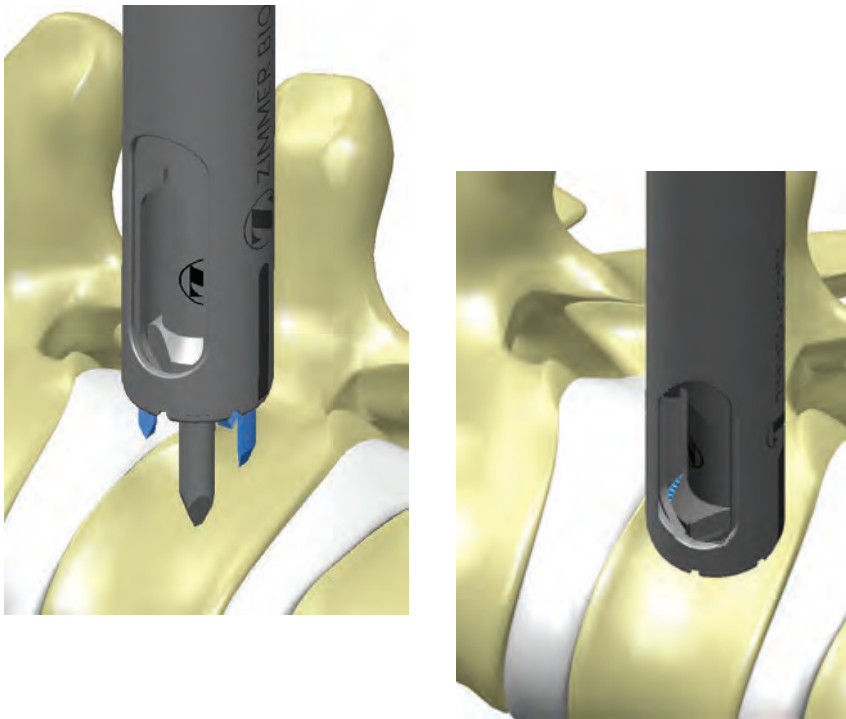
**Figure 27**  
Trocar and port preparation



**Figure 28**  
Ports inserted

### THOROSCOPY PORTAL PREPARATION AND INSERTION

- Insert two to three thoracoscopic ports in the anterior axillary line, through the intercostal spaces spanning the curve to be addressed with The Tether™ – Vertebral Body Tethering System. These ports may be used for harmonic scalpel and thoracoscopic camera introduction, as well as lung retraction. These instruments may be moved between ports; throughout the procedure as necessary. Confirm the vertebral body level using C-arm fluoroscopy in the anterior/posterior (A/P) view (Figures 27 and 28).
- Using the harmonic scalpel, incise the parietal pleura longitudinally and identify the segmental vessels along the vertebrae to be instrumented. Coagulate the segmental vessels and expose the lateral aspect of the vertebral bodies intended for instrumentation. Some surgeons choose to dissect anterior to the rib heads, in a circumferential fashion. Others choose to expose posterior to the rib head, to maintain anterior-posterior orientation, noting the proximity of the posterior wall of the vertebral body and the spinal canal. Dissection should be conducted in a sequential fashion along the length of the spinal curvature that is to be instrumented and ultimately tethered. Dissect the pleura off the lateral aspect of the vertebral bodies intended for instrumentation.



**Figure 29**  
Anchor insertion and initial screw pilot hole

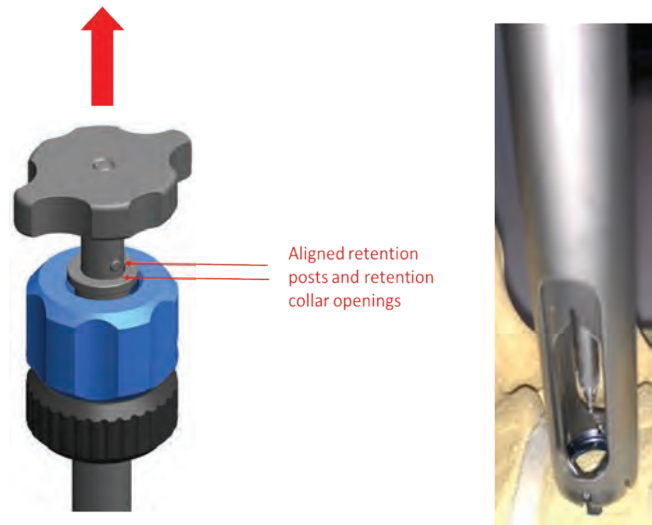
## ANCHOR INSERTION

- Introduce a port overlaying the most cephalad or caudal vertebral body to be instrumented and ultimately tethered. After each vertebral level is instrumented, the ports may be moved as necessary to the adjacent intercostal spaces, to facilitate ideal implant placement.
- With the anchor firmly secured and the appropriate awl fully inserted and retained, use the ATO to approach either the most cephalad or caudal vertebra to be instrumented, via a port marked preoperatively along the posterior-axillary line. Targeting the lateral aspect of the vertebral body, place the awl tip and anchor along the lateral body and confirm their exact position with A/P and lateral fluoroscopy. Care should be taken to ensure that the tip of the awl will travel parallel to the vertebral end plate at the level being instrumented. Introduce the awl and anchor into the lateral vertebral body, by gently impacting the awl's strike pad/dial with a mallet.
- The proper positioning of the awl and anchor should be well visualized with a thoracoscope (Figure 29). Care must be taken to ensure that the awl tip and the anchor tines remain anterior to the rib head, to ensure that neither encroaches upon the neural foramen. Keep the anchor tines from violating the disc space or the vertebral endplate.

## SURGICAL APPROACH *(continued)*



**Figure 30**  
Anchor inserter 90° handle



**Figure 31**  
Remove awl from ATO

## ANCHOR INSERTION *(continued)*

- Modulate anchor placement, depending upon the region of the spine being instrumented and the sagittal alignment presented by the patient in preoperative imaging. To recreate kyphosis, or reduce lordosis along the construct, place the anchor as far forward along the anterior column as deemed safe. Conversely, place the anchor towards the posterior column of the vertebra, if it is determined that a reduction in kyphosis or the introduction of lordosis is needed. Take care to ensure that the tines of the anchor and the tip of the awl do not encroach upon the intervertebral foramen, when placing the anchor along the posterior aspect of the vertebral body.
- Proper positioning of the anchor should be confirmed via C-arm fluoroscopy in both A/P and lateral views.
- Depending on surgeon preference, the radiolucent anchor inserter 90° handle can be used to hold the ATO, while using fluoroscopic imaging (Figure 30).
- Once the anchor and awl are fully seated and their positioning is confirmed via fluoroscopy, remove the awl by pulling back on the strike pad/dial, until the retention posts of the awl rest against the retention collar of the ATO's inner cannula. Then turn the strike pad/dial, until the retention posts find the proper alignment with the oblong opening in the ATO inner sleeve's retention collar. At this point the awl can be fully removed (Figure 31).



**Figure 32**

*Proximal integrated tap depth gauges*



**Figure 33**

*Distal integrated tap depth gauges*



**Figure 34**

*Tapping through ATO*

## SCREW PREPARATION AND INSERTION

- There are distance gauges on the proximal and distal ends of the tap (Figures 32 and 33). The proximal gauge works in conjunction with the ATO instrument's inner sleeve to show the depth that the tap has been inserted into bone.
- Insert the appropriate tap through the ATO cannula until it comes to rest against the opening in the vertebral body's lateral cortex, created by the awl tip (Figure 34).
- Rotate the ratcheting handle in a clockwise fashion, to progress the tap forward and into the bone. Using fluoroscopy for guidance, the tap should be advanced from the convexity of the curve toward the concavity, across the anterolateral aspect of the vertebral body. Care should be taken to ensure that the progression of the tap is completely parallel to the endplates of the vertebral body being instrumented.
- Careful bi-cortical purchase is desired when placing final instrumentation. After reaching the desired depth with the tap, confirm it's positioning with both A/P and lateral fluoroscopy. Once the desired positioning has been confirmed, rotate the ratcheting handle counter-clockwise to back the tap out of the bone.

## SURGICAL APPROACH (continued)



**Figure 35**  
Sounding probe



**Figure 36**  
Screwdriver and screw assembly

## SCREW PREPARATION AND INSERTION (continued)

- A ball-tipped sounding probe may be used to manually inspect the preparation site (Figure 35). There are markings on the distal end of the probe that indicate the depth to which it is inserted. These markings work in a similar fashion to the distal markings on the tap. Once preparing the vertebra for screw insertion is complete, the appropriate length screw can be selected.
- To secure the screw to the screwdriver, firmly seat the tip into the tulip of the vertebral body bone screw (Figure 36). Push forward on the screwdriver's dial and rotate the dial clockwise, until the screw is secured.



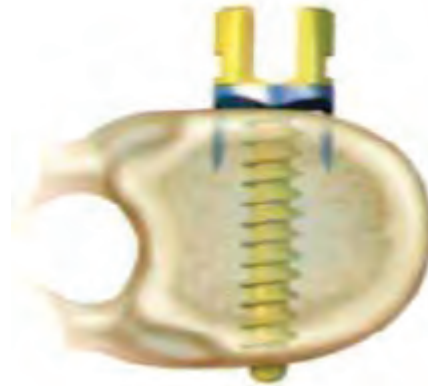


**Figure 37**  
Screw insertion through ATO



**Figure 38**  
Screw insertion

Screw fully inserted when  
insertor witness mark flush with  
ATO inner sleeve retention collar



**Figure 39**  
Bi-cortical screw placement

- Insert the screw and distal inserter end into the ATO cannula, until it comes to rest at the entry point into bone previously prepared by the awl and tap (Figure 37).
- Rotate the ratcheting handle clockwise, until the witness mark on the screwdriver meets the retention collar of the ATO inner sleeve (Figure 38). Do not over-insert the screw.
- Careful bi-cortical purchase is recommended for the placement of each screw (Figure 39). Fluoroscopy and thoracoscopic guidance should be used during the screw insertion process, to ensure that proper alignment and placement is achieved.

## SURGICAL APPROACH (continued)



**Figure 40**

Subsequent screw placement

## SCREW PREPARATION AND INSERTION (continued)

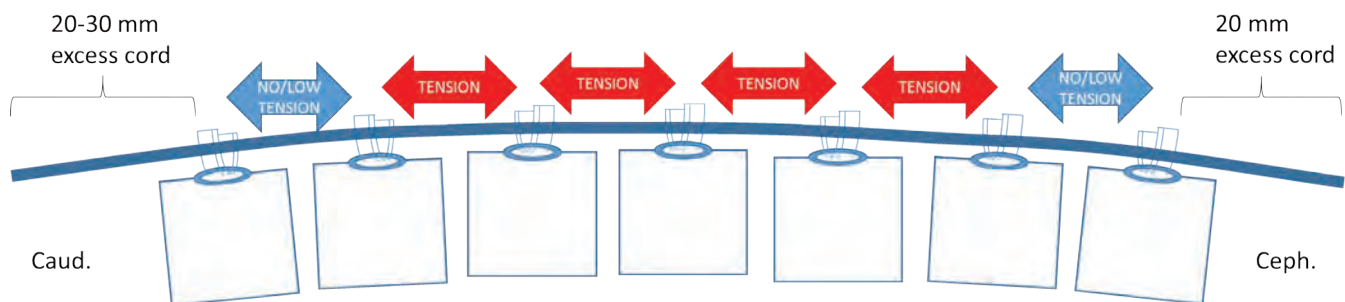
- Subsequent screws are placed in a similar manner in the vertebral bodies intended for instrumentation (Figure 40).

**Note:** Usually, 3 intercostal punctures are performed for each port's skin incision—each intercostal puncture corresponds to the placement of a screw. This process involves the removal of the trocar at the initial port site and then inserting it, through the same skin incision, to the next lower interspace. When a thoracotomy is performed, the most distal screws can be placed via the thoracotomy incision.

- Once all screws are placed, each screw is checked for proper positioning using C-arm fluoroscopy in A/P and lateral views.
- If no anchor is placed at any vertebral level, the awl can be used in a free-hand fashion. In these instances, tap insertion depth should be determined using the distal markings on the instrument.

- K-wires are available to assist with freehand introduction of a tap and the implant itself.

**Note:** In the event that a thoracic construct should need to span the diaphragm, a small opening in the diaphragm is made and the cord is passed through that opening. Care should be taken to ensure that the opening made in the diaphragm is minimal and co-axial to the eventual path of the cord, once it is tensioned. This will prevent a widening of the diaphragm opening or bunching of the diaphragm tissue against the vertebral body. Consideration should also be given to closing the diaphragmatic opening.



**Figure 41**  
Selective tensioning

## PLACEMENT AND TENSIONING OF THE FLEXIBLE PET CORD

Tensioning will provide an initial correction of the curve being treated, but more importantly it will allow for growth modulation at the levels instrumented. The amount of tension needed will vary from patient to patient and ultimately be dependent on a multitude of factors including preoperative Cobb angle, curve flexibility, curve type(s), curve location(s), skeletal maturity, and anticipated growth, among others. The forces applied to the different levels should be such that tensioning and the resulting growth modulation will be able to achieve the desired correction over time.

There are two strategies for tensioning along a tethering construct:

1. Sequential (or segmental) tensioning, where tensioning is performed one motion segment at a time
2. Multi-segment tensioning, where more than one segment is tensioned at the same time.

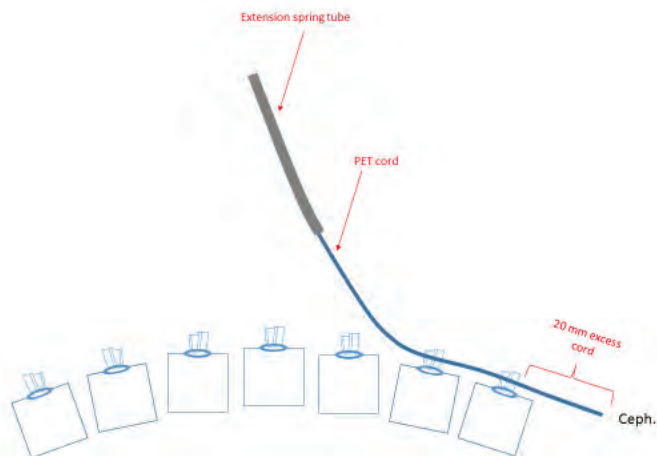
Once all desired screws have been inserted, introduce the cord to the thorax. Some surgeons may find that first passing the cord through the extension spring tube, then inserting the distal end of both the cord and the tube through the caudal 15 mm port simplifies the insertion process.

Once this has been done, use either the cord alignment rod or an endoscopic grasper to pull a sufficient working length of cord through the distal tip of the extension spring tube, so that it may be laid into the screw tulip heads. Similarly, the cord alignment rod or an endoscopic grasper may then be used to seat the cord into the tulip heads of the screw.

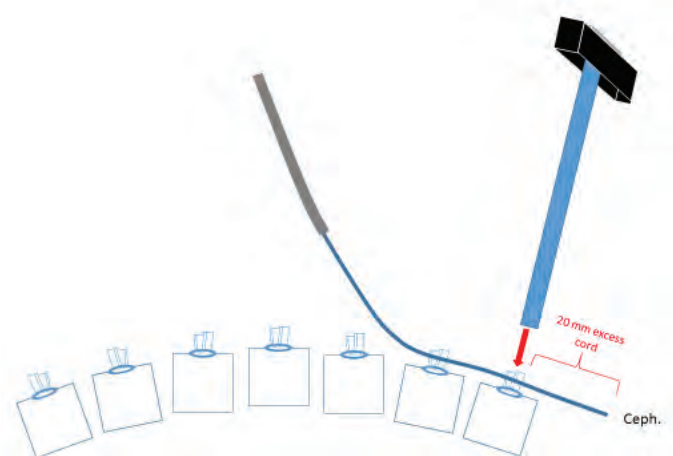
It is important to leave 20 mm of excess tether beyond the most cranial screw and 20 to 30 mm beyond the most caudal screw. This is done to provide the ability to make subsequent surgical adjustments, should the patient show signs of overcorrection post-operatively.

- To accommodate the patient's future growth, prevent overcorrection, and reduce the risk of screw plowing, take care to gently tension the cord at the most cranial and caudal motion segments (Figure 41).
- When tensioning the construct, special consideration should be given to patients with considerable growth remaining (e.g. open triradiate cartilage), lower Cobb angles, or high flexibility as excessive tension may increase the risk of overcorrection.

## SURGICAL APPROACH *(continued)*



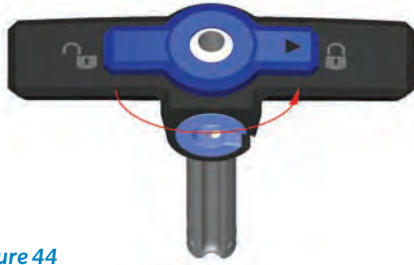
**Figure 42**  
Initial cord placement in screw heads



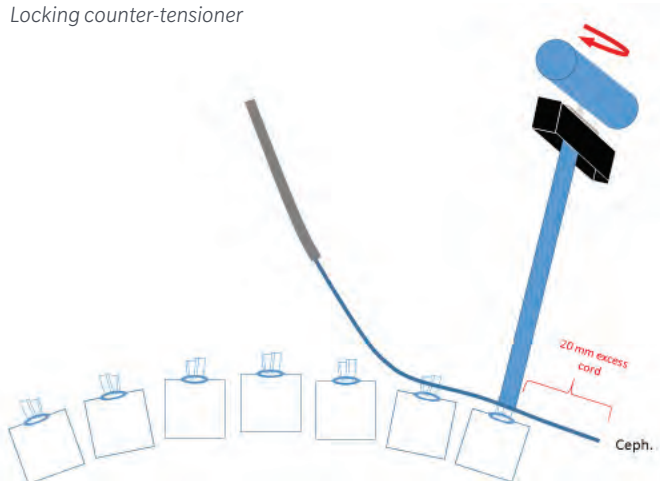
**Figure 43**  
Initial counter-tensioner introduction

### OPTION 1: SEQUENTIAL (OR SEGMENTAL) TENSIONING

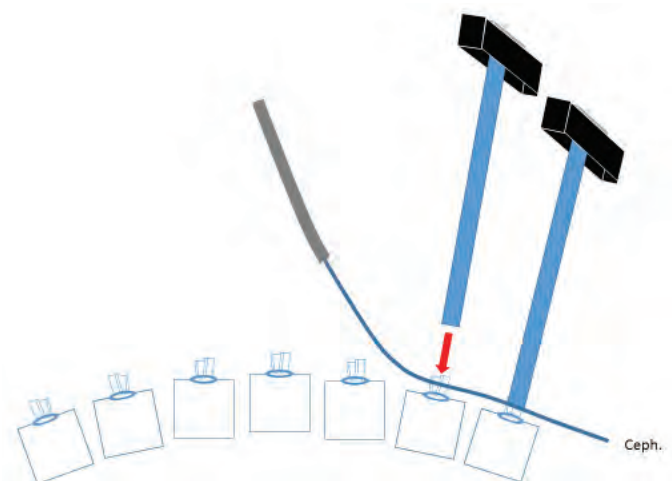
- Using the cord and tube introduction method previously described, use an endoscopic grasper, or the cord alignment rod, to seat the cord along the first two proximal screws in the construct (Figure 42).
- Introduce the first counter-tensioner to the thoracic cavity via the most cephalad port, to capture the cord and the most cranial screw (Figure 43). Ensure that the dial on the tensioner is in the unlocked position before attempting to secure it to the screw.



**Figure 44**  
Locking counter-tensioner



**Figure 45**  
Locking first set screw



**Figure 46**  
Counter-tensioner securing the second most cranial screw

- Once the distal end of the counter-tensioner is provisionally seated over the tulip head of the most cranial screw, turn the locking dial on the T-handle of the counter-tensioner, to lock the instrument in place (Figure 44).
- Introduce a set screw through the counter-tensioner's cannula using the set screw driver and T-handle. Secure the cord by first tightening the set screw at the most cranial level of the construct. Once the set screw is secured, final tighten it by rotating the T-handle clockwise, until an audible and tactile response is observed (Figure 45). Remove the set screw driver by withdrawing it from the counter-tensioner's cannula.
- Leaving the first counter-tensioner in place, introduce a second counter-tensioner to the thoracic cavity via a 15 mm port at the next caudal intercostal space. Secure the counter-tensioner to the second most cranial screw and lock it in place (Figure 46). Slide the distal end of the extension spring tube along the cord so that it rests against the caudal counter-tensioner.

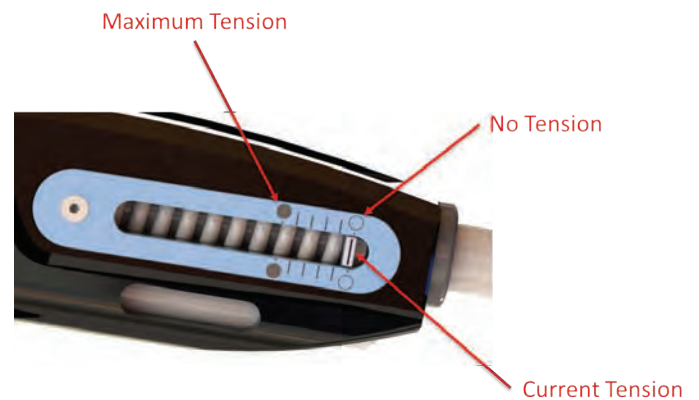
## SURGICAL APPROACH (continued)



**Figure 47**  
Cord insertion through tensioner



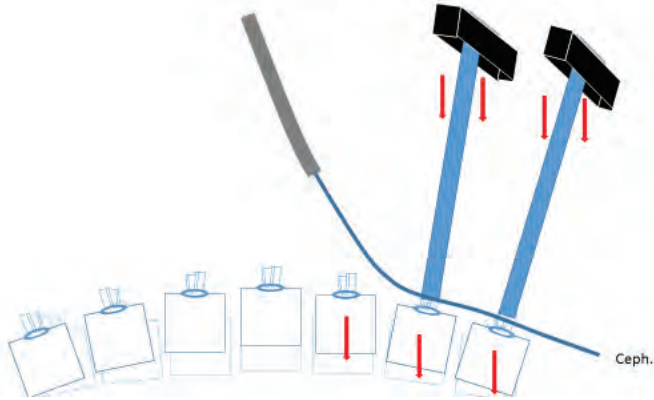
**Figure 48**  
Capture cord with tensioner rack cleats



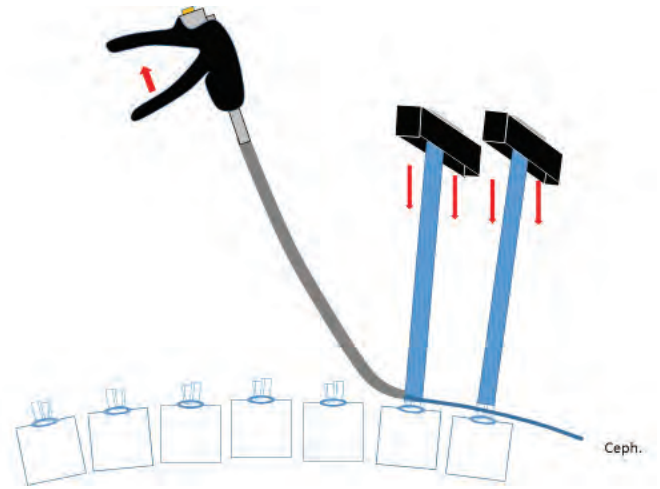
**Figure 49**  
Tensioner gauge

## OPTION 1: SEQUENTIAL (OR SEGMENTAL) TENSIONING (continued)

- Now feed the cord through the ventral port of the tensioner (Figure 47).
- Once the end of the cord emerges from the tensioner, slide the tensioner along the cord until the tensioner's ventral aspect makes contact with the tube's proximal opening. Pull the remaining slack out of the cord and feed the cord through the tensioner's cleats, so that it is secured into place and retained by the cleats (Figure 48).
- The tensioner features a gauge that indicates the achieved proximal tension, but is not a direct indicator of tension across the implant construct (Figure 26). Tension on the cord, at the implant construct, will vary depending on whether the extension spring tube or the counter-tensioner is being utilized to tension. The extension spring tube applies greater tension. Do not exceed the maximum tension marker when tensioning the cord (Figure 49).



**Figure 50**  
Lateral translation using counter-tensioners

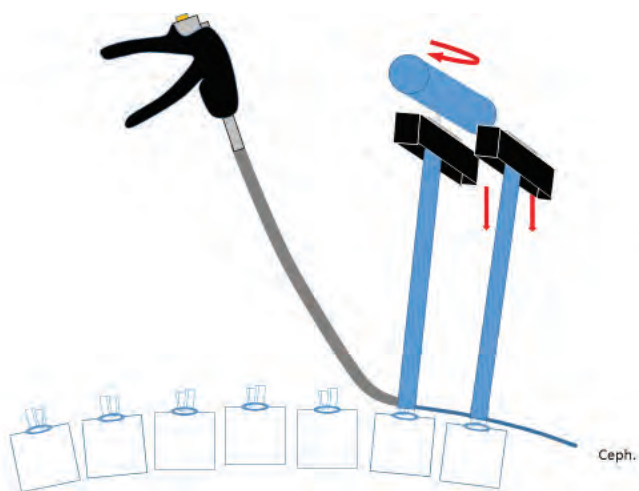


**Figure 51**  
Tension the first segment

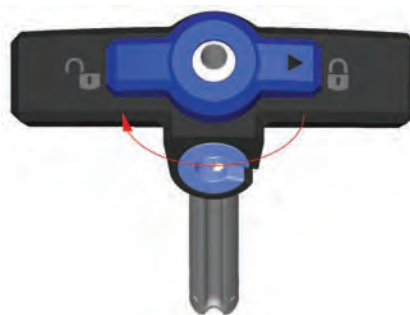
- By applying gentle downward force to the counter-tensioners during the tensioning process, the surgeon can translate the spine and reduce coronal deformity. This will help increase the likelihood of reaching the desired level of correction, without reaching the tensioner's limit (Figure 50).
- Apply gentle downward force to the counter-tensioners to translate the spine and reduce the coronal deformity before tensioning begins. Tension the cord by squeezing the handles of the tensioner until the desired correction has been achieved. Gently tension the first segment to prevent over correction and to avoid screw plowing (Figure 51).

**Note:** The fine adjustment knob may be utilized to add or reduce tension in a more precise manner, rather than squeezing the grip of the tensioner. Place the fine adjustment knob on the back of the tensioner's rack and rotate clockwise for additional tension or counter-clockwise to reduce tension.

## SURGICAL APPROACH (continued)



**Figure 52**  
Final tighten first segment



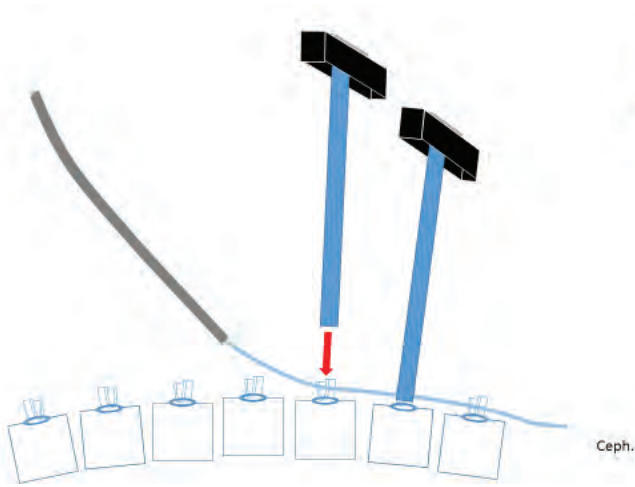
**Figure 53**  
Unlock counter-tensioner

## OPTION 1: SEQUENTIAL (OR SEGMENTAL) TENSIONING (continued)

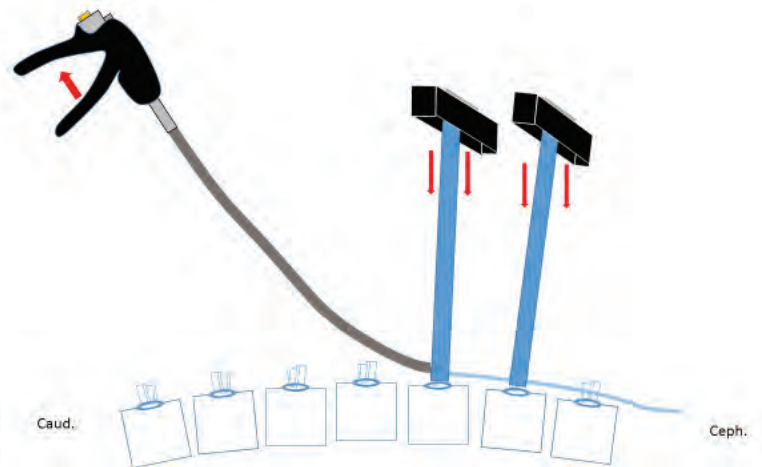
- Using the torque-limiting T-handle and the set screw driver, introduce the set screw to the most caudal counter-tensioner. Turn the torque-limiting T-handle clockwise until a tactile and auditory response is observed, indicating that the set screw has been final tightened (Figure 52). Press the silver release trigger on the tensioner and disengage the cord from the tensioner cleats. Back the distal end of the extension spring tube away from the caudal counter-tensioner. Remove the set screw driver from the most caudal counter-tensioner's cannula.
- Unlock the most cranial counter-tensioner via the locking dial on the counter-tensioner's T-handle (Figure 53). Withdraw the most cranial counter-tensioner from the cranial port.
- Prior to construct finalization, cut the excess cord using the harmonic scalpel, taking care to ensure that there is approximately 20 mm of cord left above the most cephalad screw.

**Caution:** Do not provisionally introduce a set screw to the cannula of the caudal counter-tensioner before tensioning. Similarly, do not provisionally thread a set screw into the tulip of the vertebral body bone screw, before tensioning. The cord should be tensioned until the desired correction is achieved, or the tension limit is met on the tensioner's gauge, and only then should a set screw be introduced to the construct.





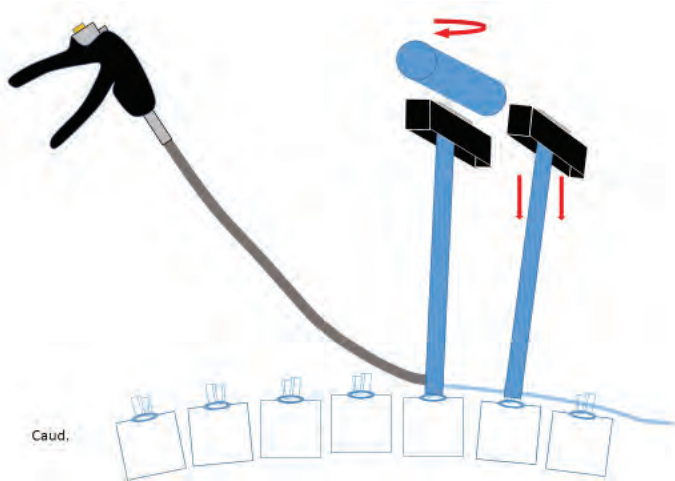
**Figure 54**  
Setting up second segment



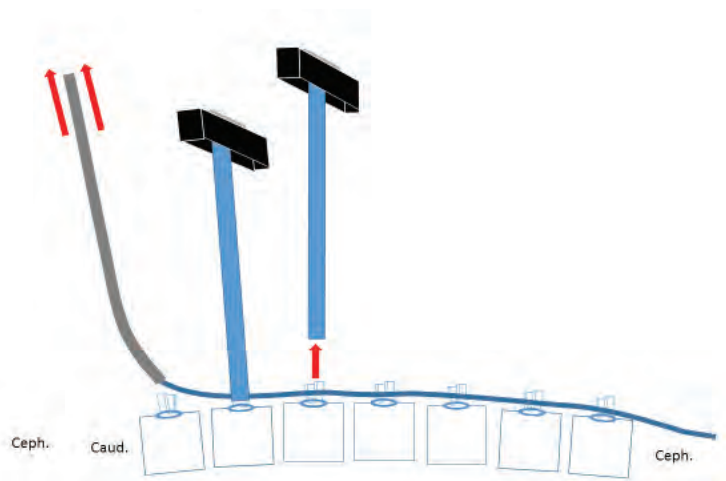
**Figure 55**  
Tensioning across second segment

- Introduce a port to the next intercostal space and use it to introduce the counter-tensioner to the next caudal screw. Place the distal end of the counter-tensioner over the next caudal screw in the construct and lock it into place, using the locking dial on the counter-tensioner's T-handle (Figure 54). With the cord still passed through the extension spring tube and provisionally captured by the tensioner, seat the distal end of the extension spring tube against the most caudal counter-tensioner. Next, ensure that the mouth of the tensioner is seated against the proximal opening of the extension spring tube, pull any slack out of the cord, and adjust the cord's placement in the tensioner's cleats as necessary.
- Apply gentle downward force to the counter-tensioners to translate the spine and reduce the coronal deformity before tensioning begins.
- Tension the cord by squeezing the handles of the tensioner, until the desired correction has been achieved, or the gauge on the tensioner shows that maximum tension has been reached (Figure 55). Using the torque-limiting T-handle and the set screw driver, introduce the set screw to the most caudal counter-tensioner.

## SURGICAL APPROACH (*continued*)



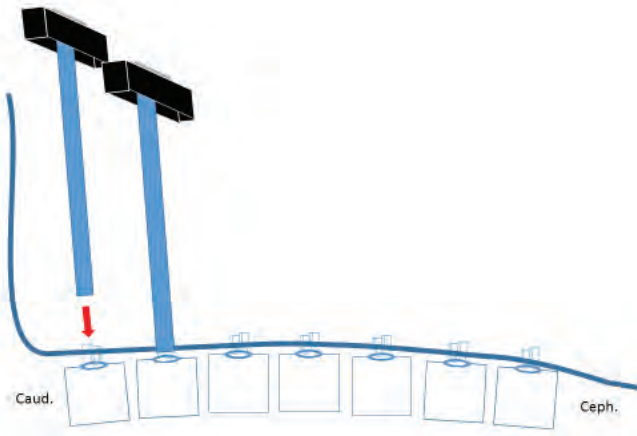
**Figure 56**  
Final tightening second segment.



**Figure 57**  
Remove counter-tensioner

## OPTION 1: SEQUENTIAL (OR SEGMENTAL) TENSIONING (*continued*)

- Using a set screw driver, introduce a set screw to the caudal screw via the caudal counter-tensioner's cannula. Turn the T-handle clockwise until a tactile and auditory response are observed. This will indicate that the set screw has been final tightened (Figure 56). Press the silver release trigger on the tensioner and disengage the cord from the tensioner cleats. Back the distal end of the extension spring tube away from the caudal counter-tensioner. Remove the set screw driver from the most caudal counter-tensioner's cannula. Unlock the most cranial counter-tensioner, via the locking dial on the counter-tensioner's T-handle. Withdraw the most cranial counter-tensioner from the cranial port.
- Repeat this process of sequential tensioning until the cord has been tensioned and secured in the second to last screw of the construct. Once tensioning has been completed from the most cephalad screw to the second most caudal screw, finalize the construct.
- Back the distal end of the extension spring tube away from the caudal counter-tensioner and withdraw the extension spring tube completely from the thorax. Unlock the most cranial counter-tensioner, via the locking dial on the counter-tensioner's T-handle. Withdraw the most cranial counter-tensioner from the cranial port (Figure 57).



**Figure 58**  
Placing final counter tensioner



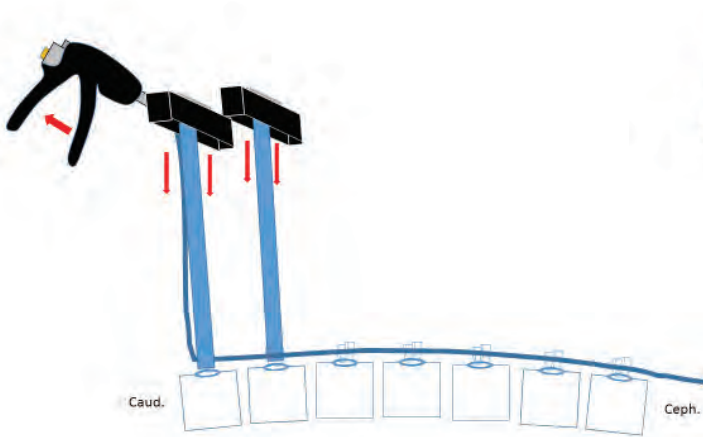
**Figure 59**  
Preparing to final tension last segment



**Figure 60**  
Tensioning final segment

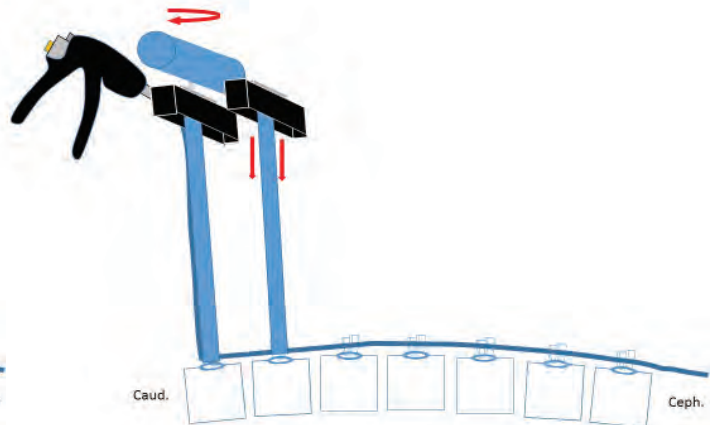
- Using the endoscopic grasper, seat the cord in the tulip of the most caudal screw. Then introduce the counter-tensioner to the thorax to capture the most caudal screw. Place the distal end of the counter-tensioner over the most caudal screw in the construct and lock it into place, using the locking dial on the counter-tensioner's T-handle (Figure 58).
- Run the cord up the caudal aspect of the most caudal counter-tensioner and out through the same port that this counter-tensioner is passing through. Lace the cord through the radial opening in the handle dock of the counter-tensioner. The distal end of the cord should now be passed through the ventral opening of the tensioner, until it exits at the back of the tensioner (Figure 59).
- While still holding the end of the cord, slide the tensioner to the integrated dock on the counter-tensioner, and then seat the ventral port into the dock. Pull the distal end of the cord taut and seat the cord in the grasping cleats of the tensioner instrument (Figure 60).

## SURGICAL APPROACH (continued)



**Figure 61**

Finalize the caudal aspect of the construct



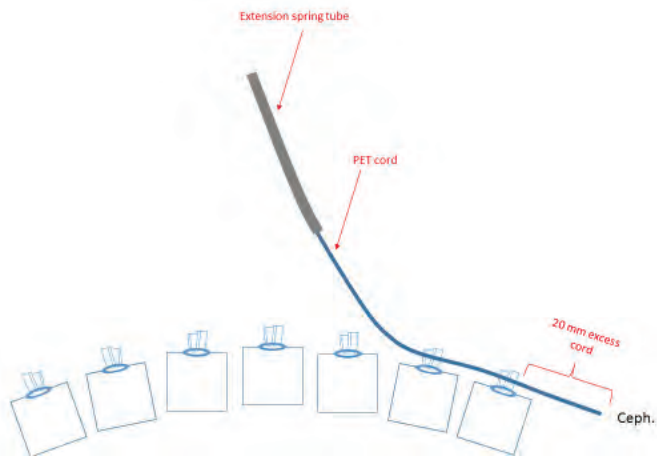
**Figure 62**

Final tensioning of caudal segment

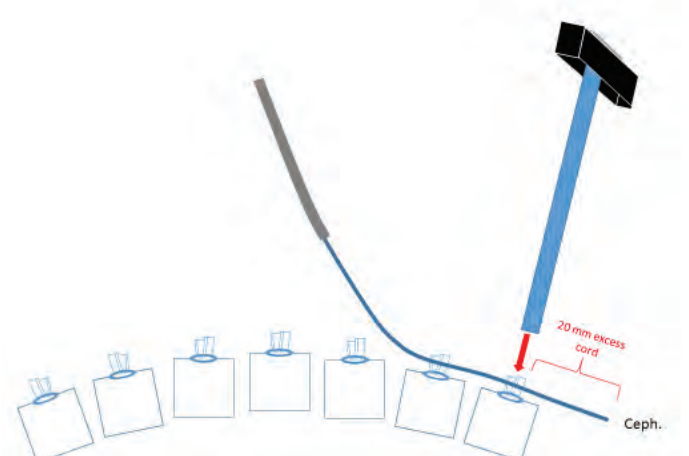
### OPTION 1: SEQUENTIAL (OR SEGMENTAL) TENSIONING (continued)

- Apply gentle downward force to the counter-tensioners, to translate the spine and reduce the coronal deformity before tensioning begins. Squeeze the handles of the tensioner until the desired correction has been achieved. This last segment should be very gently tensioned, in order to prevent over correction and to avoid screw plowing (Figure 61).
 

**Note:** The fine adjustment knob may be utilized to add or reduce tension in a more precise manner, rather than squeezing the grip of the tensioner. Place the fine adjustment knob on the back of the tensioner's rack and rotate clockwise for additional tension or counter-clockwise to reduce tension.
- While maintaining downward pressure, introduce a set screw to the last screw via the caudal counter-tensioner's cannula. Rotate the T-handle until a tactile and auditory response is observed, indicating that the set screw has been final tightened (Figure 62). Withdraw the T-handle and set screw driver from the most caudal counter-tensioner and then remove both counter-tensioners.
- Now that the construct has been finalized, cut the excess cord using the harmonic scalpel, taking care to ensure that there is approximately 20-30 mm of cord left beyond the final caudal screw in the construct.



**Figure 63**  
Seating cord

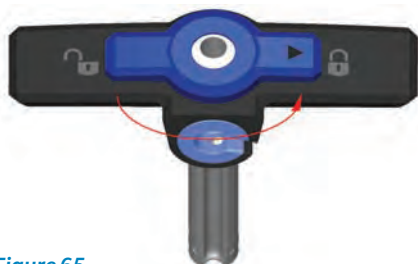


**Figure 64**  
Introduce first counter-tensioner

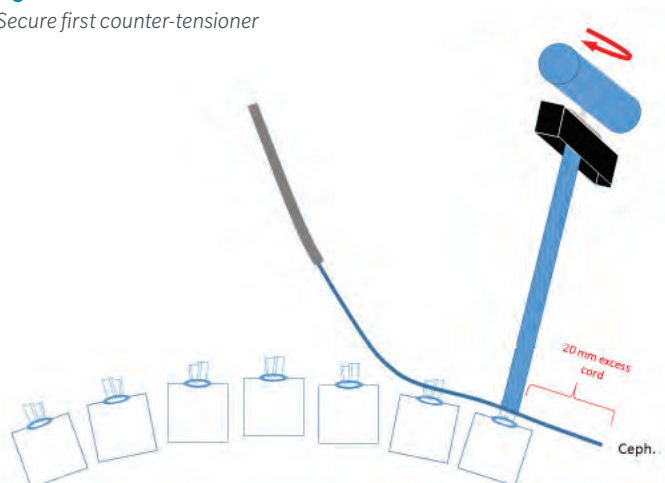
## OPTION 2: MULTI-SEGMENT TENSIONING

- After seating all of the screws, using the cord and tube introduction method previously described, select an endoscopic grasper or the cord alignment rod to seat the cord along the first two proximal screws in the construct (Figure 63).
- Introduce the counter-tensioner to the thoracic cavity via the most cephalad port, in order to capture the cord and the most cephalad screw (Figure 64). Ensure that the dial on the tensioner is in the unlocked position before attempting to secure it to the screw.

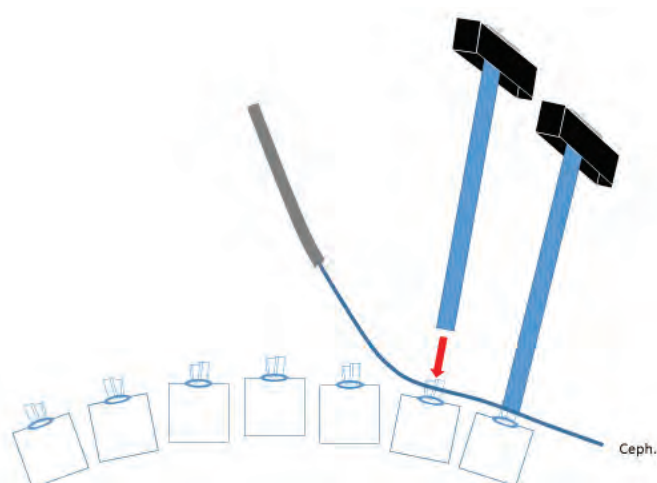
## SURGICAL APPROACH (continued)



**Figure 65**  
Secure first counter-tensioner



**Figure 66**  
Secure the first set screw



**Figure 67**  
Secure the second counter-tensioner

## OPTION 2: MULTI-SEGMENT TENSIONING (continued)

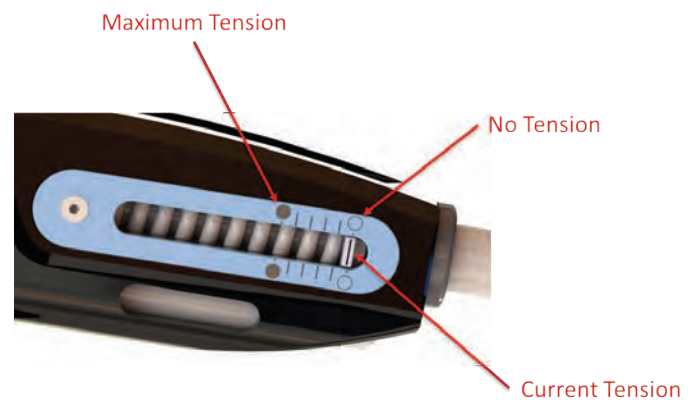
- Once the distal end of the counter-tensioner is provisionally seated over the tulip head of the second most cranial screw, turn the locking dial on the T-handle of the counter-tensioner, to lock it in place (Figure 65).
- Introduce a set screw through the counter-tensioner's cannula using the set screw driver and T-handle. Secure the cord by final tightening the set screw at the most cranial level of the construct. Once the set screw is secured, final tighten it by rotating the T-handle clockwise, until an audible and tactile response is observed. Remove the set screw driver by withdrawing it from the counter-tensioner's cannula (Figure 66).
- Prior to construct finalization, cut the excess cord using the harmonic scalpel, taking care to ensure that there is approximately 20 mm of cord left above the most cephalad screw.
- Leaving the first counter-tensioner in place, introduce a second counter-tensioner to the thoracic cavity via a 15 mm port at the next caudal intercostal space. Secure the counter-tensioner to the second most cranial screw and lock it in place (Figure 67). Slide the distal end of the extension spring tube along the cord until it rests against the caudal counter-tensioner.



**Figure 68**  
Cord insertion through tensioner



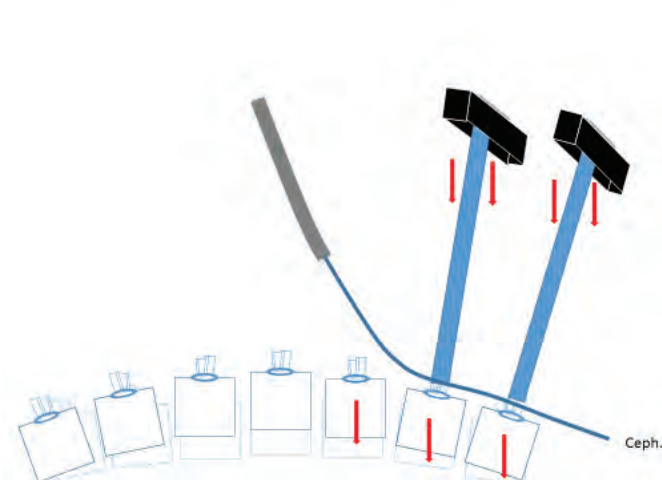
**Figure 69**  
Capture cord with tensioner rack cleats



**Figure 70**  
Tensioner gauge

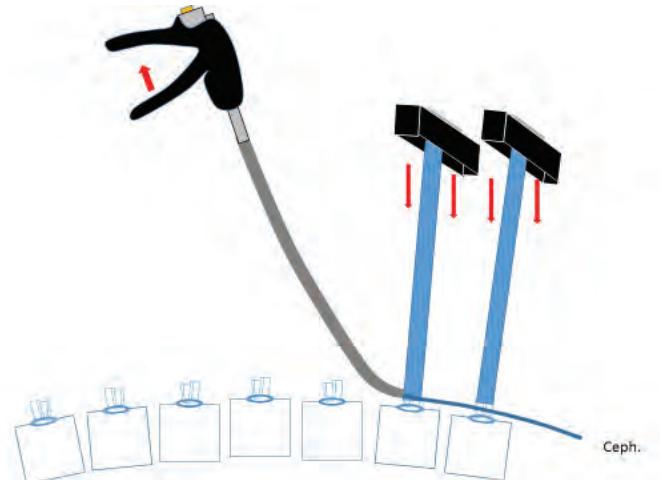
- Feed the cord through the ventral port of the tensioner (Figure 68).
- Once the end of the cord emerges from the tensioner, slide the tensioner along the cord until the tensioner's ventral aspect makes contact with the tube's proximal opening. Pull remaining slack out of the cord and feed the cord through the tensioner's cleats, so that it is secured into place and retained by the cleats (Figure 69).
- The tensioner features a gauge that indicates the extent to which the instrument has created proximal tension and is not a direct indicator of tension across the implant construct (Figure 26). The tension on the cord at the implant construct will vary depending on whether the extension spring tube, or the counter-tensioner is being utilized to tension. The extension spring tube applies greater tension. Do not exceed the maximum tension marker when tensioning the cord (Figure 70).
- As noted previously, when tensioning the construct special consideration should be given to patients with considerable growth remaining (e.g. open triradiate cartilage), lower Cobb angles, or high flexibility as excessive tension may increase the risk of overcorrection.

## SURGICAL APPROACH (continued)



**Figure 71**

Lateral translation using counter-tensioners



**Figure 72**

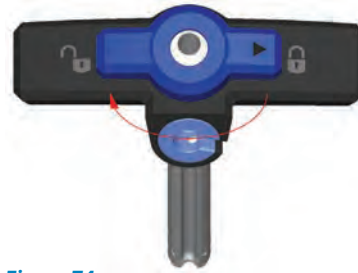
Tensioning first segment

## OPTION 2: MULTI-SEGMENT TENSIONING (continued)

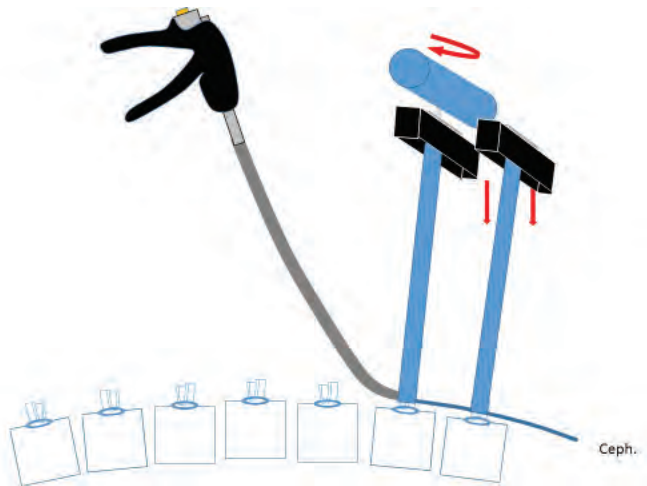
- By applying gentle downward force to the counter-tensioners during the tensioning process, the surgeon can translate the spine and reduce the coronal deformity before tensioning begins. This will help increase the likelihood of reaching the desired level of correction, without reaching the tensioner's limit (Figure 71).
- Apply gentle downward force to the counter-tensioners to translate the spine and reduce the coronal deformity before tensioning begins. Squeeze the handles of the tensioner until the desired correction has been achieved. This first segment should be very gently tensioned in order to prevent over correction and to avoid screw plowing (Figure 72).

**Note:** The fine adjustment knob may be utilized to add or reduce tension in a more precise manner, rather than squeezing the grip of the tensioner. Place the fine adjustment knob on the back of the tensioner's rack and rotate clockwise for additional tension or counter-clockwise to reduce tension.

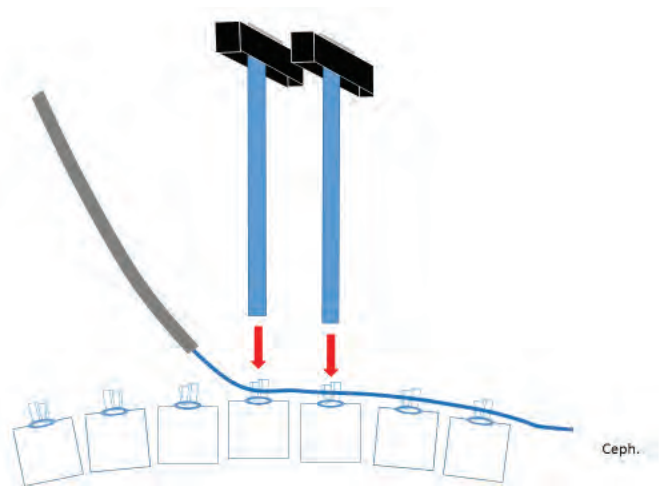




**Figure 74**  
Unlock counter-tensioner



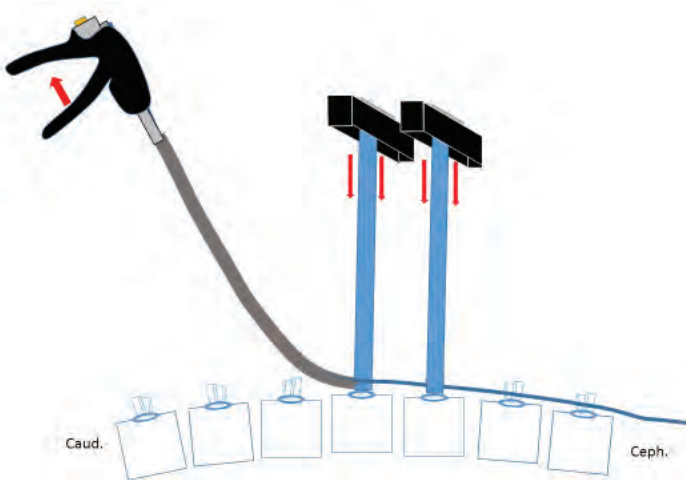
**Figure 73**  
Final tighten the first segment



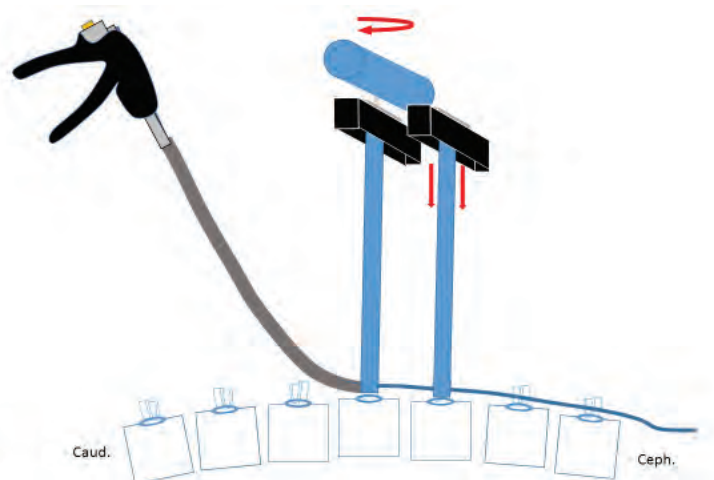
**Figure 75**  
Place counter tensioners along apex

- Using the torque-limiting T-handle and the set screw driver, introduce the set screw to the most caudal counter-tensioner. Turn the torque-limiting T-handle clockwise until a tactile and auditory response is observed, indicating that the set screw has been final tightened (Figure 73). Press the silver release trigger on the tensioner and disengage the cord from the tensioner cleats. Back the distal end of the extension spring tube away from the caudal counter-tensioner. Remove the set screw driver from the most caudal counter-tensioner's cannula.
- Unlock both counter-tensioners via the locking dial on their respective T-handles. Withdraw both counter-tensioners from their respective ports (Figure 74).
- The two counter-tensioners should now be introduced to the thoracic cavity via 15 mm ports at intercostal spaces over the apex of the scoliotic curve. If the curve features a single apical vertebra, rather than an apical disc, place the counter-tensioners at the apical vertebra and the vertebra immediately superior to the apex. Secure the counter-tensioners by locking them into place (Figure 75). Once the counter-tensioners are secured, bring the distal end of the extension spring tube to rest against the caudal counter-tensioner.

## SURGICAL APPROACH (continued)



**Figure 76**  
Multi-segment tensioning

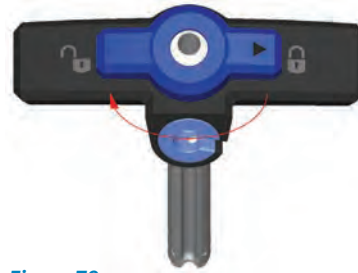


**Figure 77**  
Finalize the first segments of the construct

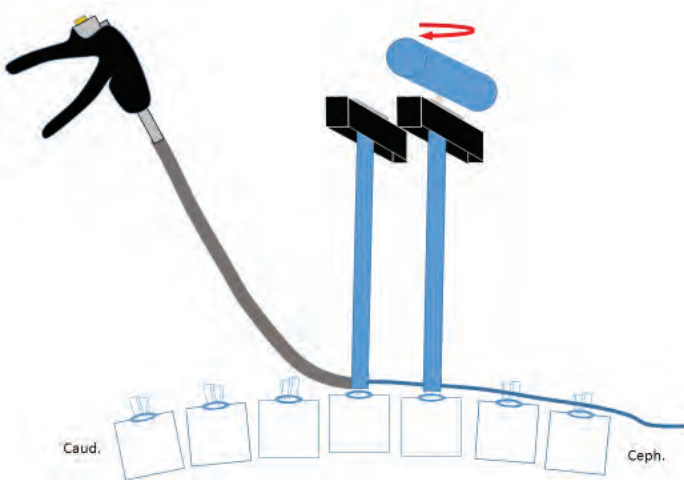
### OPTION 2: MULTI-SEGMENT TENSIONING (continued)

- Apply gentle downward force to the counter-tensioners to translate the spine and reduce the coronal deformity before tensioning begins.
- Squeeze the handles of the tensioner until the desired correction has been achieved, or the tension gauge shows that maximum tension has been reached (Figure 76).
- Using the torque-limiting T-handle and the set screw driver, introduce the set screw to the most caudal counter-tensioner. Turn the torque-limiting T-handle clockwise until a tactile and auditory response is observed, indicating that the set screw has been final tightened (Figure 77).

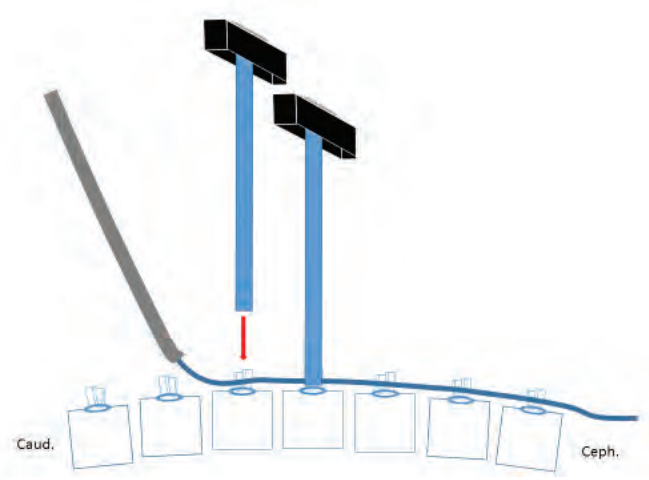
**Caution:** Do not provisionally introduce a set screw to either counter-tensioner cannulas before tensioning. Similarly, do not provisionally thread a set screw into the tulip of either vertebral body bone screw before tensioning. The cord should be tensioned until the desired correction is achieved, or the tension limit is met on the tensioner's gauge, and only then should a set screw be introduced to the construct.



**Figure 79**  
Unlock counter-tensioner



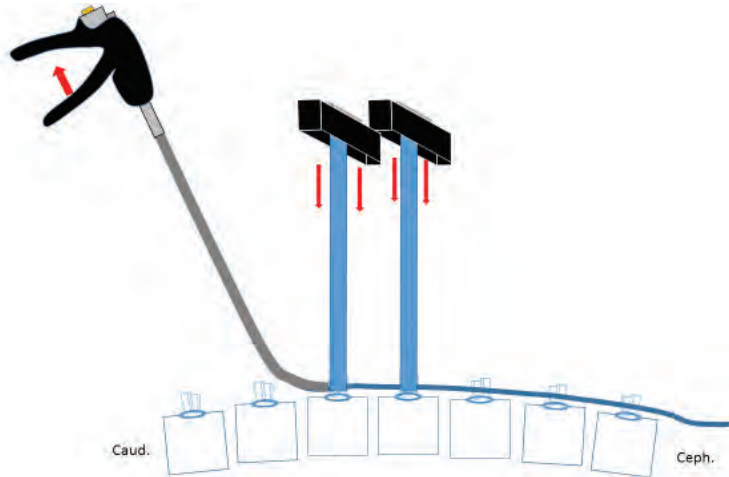
**Figure 78**  
Final tightening of set screw



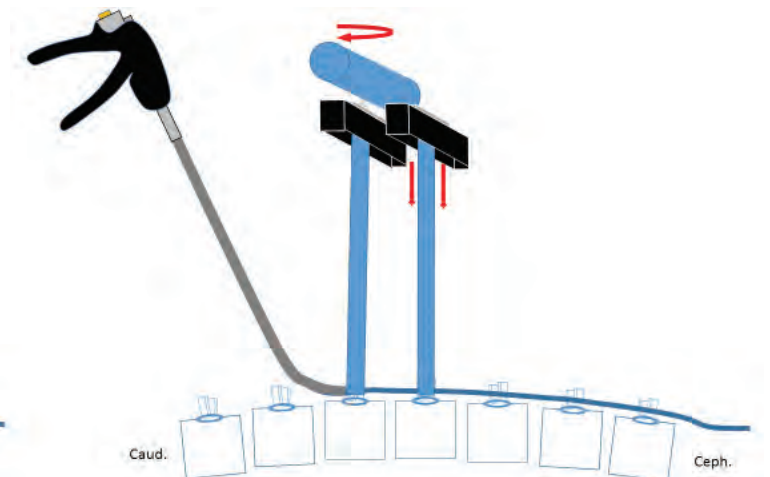
**Figure 80**  
Introduce counter-tensioner to next caudal screw

- Using the torque-limiting T-handle and the set screw driver, introduce the set screw to the most cephalad counter-tensioner. Turn the torque-limiting T-handle clockwise until a tactile and auditory response is observed, indicating that the set screw has been final tightened.
- Press the silver release trigger on the tensioner and disengage the cord from the tensioner cleats. Back the distal end of the extension spring tube away from the caudal counter-tensioner. Remove the set screw driver from the most cephalad counter-tensioner's cannula (Figure 78).
- Unlock the most cranial counter-tensioner via the locking dial on the counter-tensioner's T-handle. Withdraw the most cranial counter-tensioner from the cranial port (Figure 79).
- Introduce a 15 mm port to the next intercostal space that provides access to the vertebra caudal to the apical vertebra. Use this new port to introduce the counter-tensioner to the next caudal screw (Figure 80). Place the distal end of the counter-tensioner over this screw and lock it into place, using the locking dial on the counter-tensioner's T-handle. With the cord still passed through the extension spring tube and provisionally captured by the tensioner, seat the distal end of the extension spring tube against the most caudal counter-tensioner. Ensure that the mouth of the tensioner is seated against the proximal opening of the extension spring tube, pull any slack out of the cord, and adjust the cord's placement in the tensioner's cleats as necessary.

## SURGICAL APPROACH *(continued)*



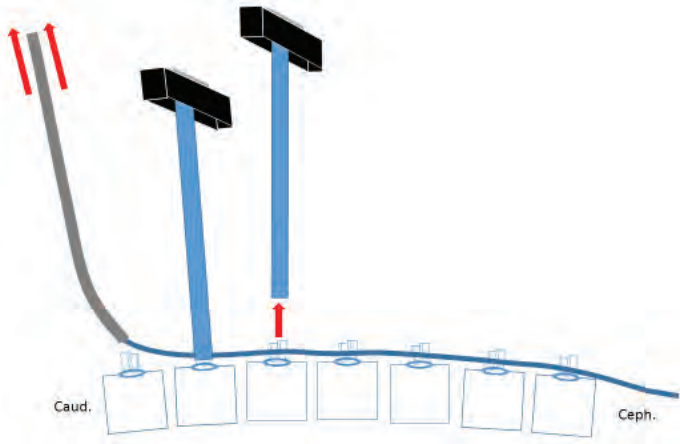
**Figure 81**  
Tension segmentally caudal to apex



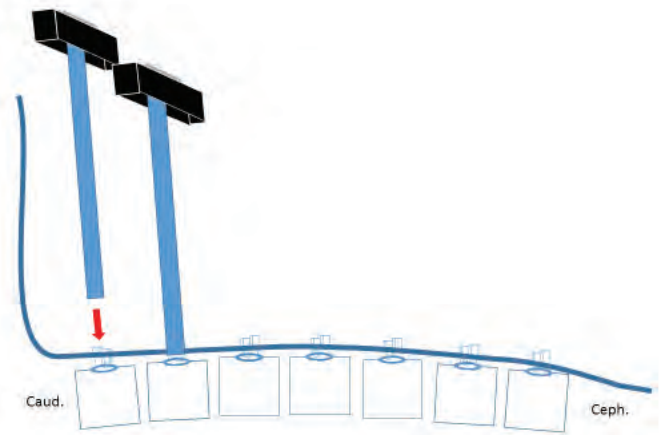
**Figure 82**  
Finalize segment caudal to apex

## OPTION 2: MULTI-SEGMENT TENSIONING *(continued)*

- Apply gentle downward force to the counter-tensioners to translate the spine and reduce the coronal deformity before tensioning begins.
- Now tension the cord by squeezing the handles of the tensioner until the desired correction has been achieved, or the witness mark shows that maximum tension has been reached. Using the torque-limiting blue T-handle and the set screw driver, introduce the set screw to the most caudal counter-tensioner (Figure 81).
- Using a set screw driver, introduce a set screw to the caudal screw via the caudal counter-tensioner's cannula. Turn the T-handle clockwise until a tactile and auditory response is observed. This will indicate that the set screw has been final tightened. Remove the set screw driver from the most caudal counter-tensioner's cannula. Unlock the most cranial counter-tensioner, via the locking dial on the counter-tensioner's T-handle. Withdraw the most cranial counter-tensioner from the cranial port (Figure 82).
- Repeat this process of sequential tensioning until the cord has been tensioned and secured in the second-to-last screw of the construct. Finalize the construct once tensioning has been completed from the most cephalad screw to the second most caudal screw.

**Figure 83**

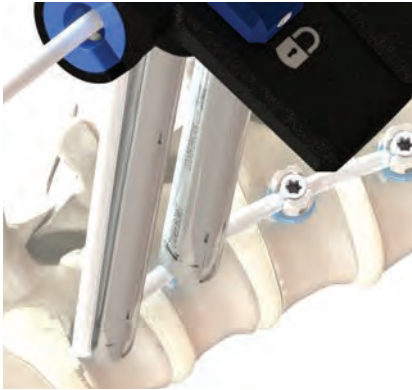
*Remove cephalad counter-torque*

**Figure 84**

*Place counter-tensioner at caudal vertebral body bone screw*

- Back the distal end of the extension spring tube away from the caudal counter-tensioner and withdraw the extension spring tube from the thorax. Unlock the most cranial counter-tensioner, via the locking dial on the counter-tensioner's T-handle. Withdraw the most cranial counter-tensioner from the cranial port (Figure 83).
- Using the endoscopic grasper, seat the cord in the tulip of the most caudal screw. Then introduce the counter-tensioner to the thorax to capture the most caudal screw. Place the distal end of the counter-tensioner over the most caudal screw in the construct and lock it in place, using the locking dial on the counter-tensioner's T-handle (Figure 84).

## SURGICAL APPROACH (continued)



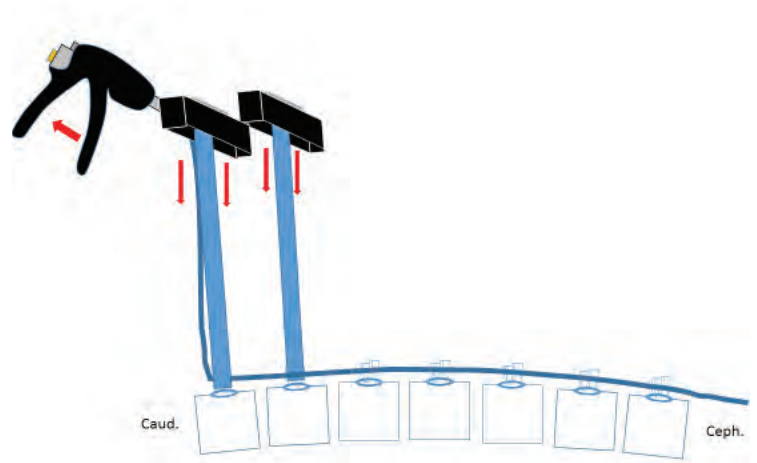
**Figure 85**

Prepare to final tension the last segment



**Figure 86**

Tension the final segment



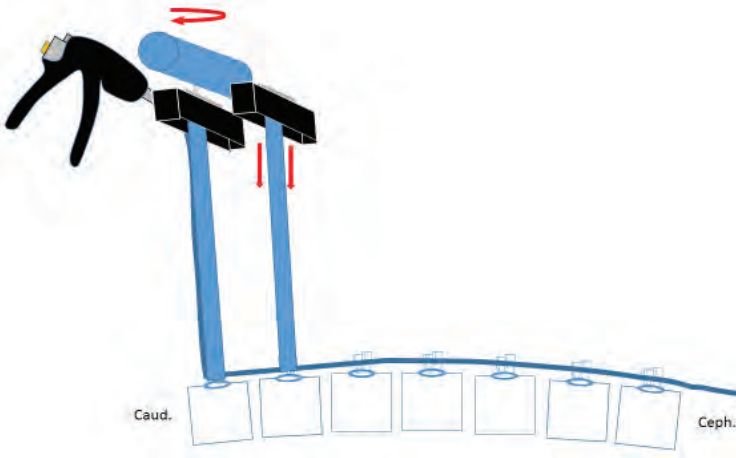
**Figure 87**

Tension caudal aspect of construct

## OPTION 2: MULTI-SEGMENT TENSIONING (continued)

- Run the cord up the caudal aspect of the counter-tensioner and out through the same port that the counter-tensioner is passing through. The cord should be laced through the radial opening in the handle dock of the counter-tensioner. Pass the distal end of the cord through the ventral opening of the tensioner, until it exits at the back of the tensioner (Figure 85).
- While still holding the end of the cord, slide the tensioner to the integrated dock on the counter-tensioner, and then seat the ventral port into the dock. Pull the distal end of the cord taut and seat the cord in the grasping cleats of the tensioner instrument (Figure 86).
- Apply gentle downward force to the counter-tensioners, to translate the spine and reduce the coronal deformity before tensioning begins. Now tension the cord by squeezing the handles of the tensioner until the desired correction has been achieved. This last segment should be very gently tensioned, in order to prevent over correction and to avoid screw plowing (Figure 87).

**Note:** The fine adjustment knob may be utilized to add or reduce tension in a more precise manner, rather than squeezing the grip of the tensioner. Place the fine adjustment knob on the back of the tensioner's rack and rotate clockwise for additional tension or counter-clockwise to reduce tension.



**Figure 88**  
Finalize caudal segment

- While maintaining this downward pressure, introduce a set screw to the last screw via the caudal counter-tensioner's cannula. Rotate the T-handle until a tactile and auditory response is observed, indicating that the set screw has been final tightened (Figure 88). Withdraw the T-handle and set screw driver from the most caudal counter-tensioner and then remove both counter-tensioners.
- Now that the construct has been finalized, cut the excess cord using the harmonic scalpel, taking care to ensure that there is approximately 20-30 mm of cord left beyond the most caudal screw in the construct.



**Figure 89**  
Tensioner rack fully extended

## CLOSURE

- The wound is closed using standard techniques.

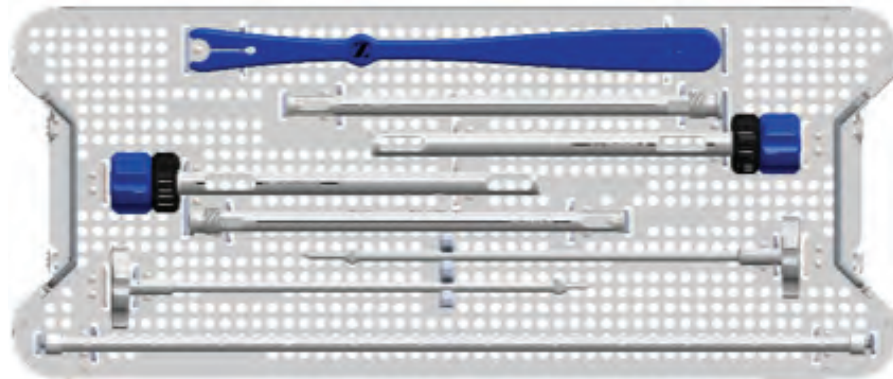
## REVISION/REMOVAL

- Introduce the counter-tensioner to the desired screw. Use the T-handle and set screw driver to loosen the set screw and remove. Introduce the screwdriver to the thorax, through a 15 mm trocar to remove the screw in a freehand fashion. The staple may be removed by an endoscopic grasper, or via the ATO.

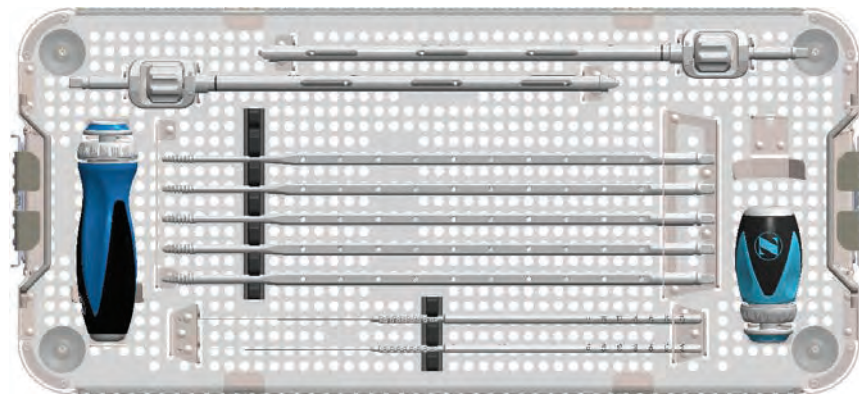
## SPECIAL CLEANING INSTRUCTIONS FOR TENSIONER

- Work the rack in and out while manually cleaning the tensioner. The tensioner rack should be fully extended during automated cleaning (Figure 89).

## KIT CONTENTS



Upper



Lower

### The Tether Instrument Kit 1 - Cannulated Kit Number: PCR200H1101

DESCRIPTION	QTY	PART NUMBER
Ratcheting Handle	1	230H5502
Ratcheting Handle, Palm	1	230H5503
5.0 mm Tap, Cannulated	1	230H2050
5.5 mm Tap, Cannulated	1	230H2055
6.0 mm Tap, Cannulated	1	230H2060
6.5 mm Tap, Cannulated	1	230H2065
7.0 mm Tap, Cannulated	1	230H2070
Screwdriver	2	230H4002
Sounder	2	230H3003
Anchor Inserter 90° Handle	1	230H1010
Anchor Inserter Outer Sleeve	2	230H2001
Anchor Inserter Inner Sleeve	2	230H2002
Awl	1	230H1004
Awl Long	1	230H1006
K-wire Dispenser	1	230H3304
K-wire	15	230H3301

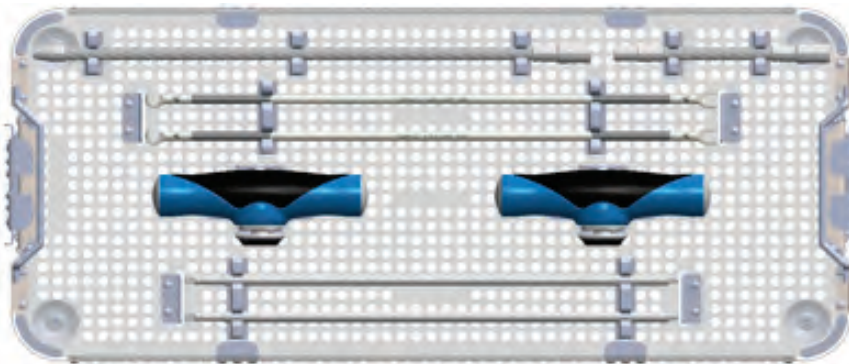
### The Tether Instrument Kit 1 – Non-cannulated Kit Number: PCR200H1102

DESCRIPTION	QTY	PART NUMBER
Ratcheting Handle	1	230H5502
Ratcheting Handle, Palm	1	230H5503
4.5 mm Tap, Non-Cannulated	1	230H2145
5.0 mm Tap, Non-Cannulated	1	230H2150
5.5 mm Tap, Non-Cannulated	1	230H2155
6.0 mm Tap, Non-Cannulated	1	230H2160
6.5 mm Tap, Non-Cannulated	1	230H2165
7.0 mm Tap, Non-Cannulated	1	230H2170
Screwdriver	2	230H4002
Sounder	2	230H3003
Anchor Inserter 90° Handle	1	230H1010
Anchor Inserter Outer Sleeve	2	230H2001
Anchor Inserter Inner Sleeve	2	230H2002
Awl	1	230H1004
Awl Long	1	230H1006





Upper



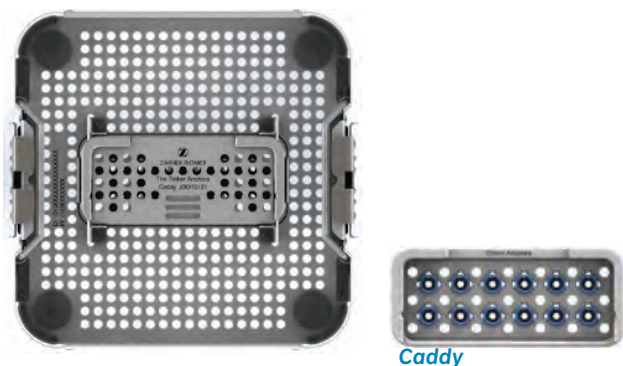
Lower

### The Tether Instrument Kit 2

**Kit Number: PCR200H2101**

DESCRIPTION	QTY	PART NUMBER
Torque-Limiting Handle	2	230H5501
Set Screw Driver	2	230H4001
Cord Alignment Rod	2	230H4004
Extension Spring Tube Long	1	230H6007
Extension Spring Tube Short	1	230H6008
Counter-Tensioner	2	230H6002
Cord Tensioner	2	230H6003
Fine Adjustment Knob	1	230H6001

## KIT CONTENTS (continued)



### Implant Kit 1 – Vertebral Body Anchors Kit Number: PCR200H3101

DESCRIPTION	QTY	PART NUMBER
12 mm Vertebral Body Anchor	12	203H0012

### Implant Kit 2 – Vertebral Body Bone Screws Kit Number: PCR200H3102

The Vertebral Body Assembly includes a Bone Screw and a Set Screw. All implants are sterile packaged.

DESCRIPTION	QTY	PART NUMBER
300 mm Flexible PET Cord	2	204H0300
ø5.5 mm x 20 mm Vertebral Body Assembly	2	211H5520
ø5.5 mm x 22.5 mm Vertebral Body Assembly	2	211H5522
ø5.5 mm x 25 mm Vertebral Body Assembly	4	211H5525
ø5.5 mm x 27.5 mm Vertebral Body Assembly	5	211H5527
ø5.5 mm x 30 mm Vertebral Body Assembly	5	211H5530
ø5.5 mm x 32.5 mm Vertebral Body Assembly	5	211H5532
ø5.5 mm x 35 mm Vertebral Body Assembly	5	211H5535
ø5.5 mm x 37.5 mm Vertebral Body Assembly	5	211H5537
ø5.5 mm x 40 mm Vertebral Body Assembly	4	211H5540
ø5.5 mm x 42.5 mm Vertebral Body Assembly	2	211H5542
ø5.5 mm x 45 mm Vertebral Body Assembly	2	211H5545
ø5.5 mm x 47.5 mm Vertebral Body Assembly	1	211H5547
ø5.5 mm x 50 mm Vertebral Body Assembly	1	211H5550
ø6.0 mm x 20 mm Vertebral Body Assembly	2	211H6020
ø6.0 mm x 22.5 mm Vertebral Body Assembly	3	211H6022
ø6.0 mm x 25 mm Vertebral Body Assembly	4	211H6025
ø6.0 mm x 27.5 mm Vertebral Body Assembly	4	211H6027
ø6.0 mm x 30 mm Vertebral Body Assembly	5	211H6030
ø6.0 mm x 32.5 mm Vertebral Body Assembly	5	211H6032
ø6.0 mm x 35 mm Vertebral Body Assembly	4	211H6035
ø6.0 mm x 37.5 mm Vertebral Body Assembly	4	211H6037
ø6.0 mm x 40 mm Vertebral Body Assembly	4	211H6040
ø6.0 mm x 42.5 mm Vertebral Body Assembly	2	211H6042
ø6.0 mm x 45 mm Vertebral Body Assembly	2	211H6045
ø6.0 mm x 47.5 mm Vertebral Body Assembly	1	211H6047
ø6.0 mm x 50 mm Vertebral Body Assembly	1	211H6050

### Implant Kit 3 - Vertebral Body Bone Screws Kit Number: PCR200H3103

The Vertebral Body Assembly includes a Bone Screw and a Set Screw. All implants are sterile packaged.

DESCRIPTION	QTY	PART NUMBER
300 mm Flexible PET Cord	2	204H0300
ø6.0 mm x 20 mm Vertebral Body Assembly	2	211H6020
ø6.0 mm x 22.5 mm Vertebral Body Assembly	3	211H6022
ø6.0 mm x 25 mm Vertebral Body Assembly	4	211H6025
ø6.0 mm x 27.5 mm Vertebral Body Assembly	6	211H6027
ø6.0 mm x 30 mm Vertebral Body Assembly	6	211H6030
ø6.0 mm x 32.5 mm Vertebral Body Assembly	6	211H6032
ø6.0 mm x 35 mm Vertebral Body Assembly	7	211H6035
ø6.0 mm x 37.5 mm Vertebral Body Assembly	6	211H6037
ø6.0 mm x 40 mm Vertebral Body Assembly	6	211H6040
ø6.0 mm x 42.5 mm Vertebral Body Assembly	4	211H6042
ø6.0 mm x 45 mm Vertebral Body Assembly	4	211H6045
ø6.0 mm x 47.5 mm Vertebral Body Assembly	4	211H6047
ø6.0 mm x 50 mm Vertebral Body Assembly	1	211H6050
ø6.5 mm x 20 mm Vertebral Body Assembly	2	211H6520
ø6.5 mm x 22.5 mm Vertebral Body Assembly	2	211H6522
ø6.5 mm x 25 mm Vertebral Body Assembly	2	211H6525
ø6.5 mm x 27.5 mm Vertebral Body Assembly	2	211H6527
ø6.5 mm x 30 mm Vertebral Body Assembly	2	211H6530
ø6.5 mm x 32.5 mm Vertebral Body Assembly	2	211H6532
ø6.5 mm x 35 mm Vertebral Body Assembly	2	211H6535
ø6.5 mm x 37.5 mm Vertebral Body Assembly	2	211H6537
ø6.5 mm x 40 mm Vertebral Body Assembly	2	211H6540
ø6.5 mm x 42.5 mm Vertebral Body Assembly	2	211H6542
ø6.5 mm x 45 mm Vertebral Body Assembly	2	211H6545
ø6.5 mm x 47.5 mm Vertebral Body Assembly	2	211H6547
ø6.5 mm x 50 mm Vertebral Body Assembly	1	211H6550

### Implant Kit 4 - Vertebral Body Bone Screws Kit Number: PCR200H3104

The Vertebral Body Assembly includes a Bone Screw and a Set Screw. All implants are sterile packaged.

DESCRIPTION	QTY	PART NUMBER
300 mm Flexible PET Cord	2	204H0300
ø6.5 mm x 20 mm Vertebral Body Assembly	1	211H6520
ø6.5 mm x 22.5 mm Vertebral Body Assembly	3	211H6522
ø6.5 mm x 25 mm Vertebral Body Assembly	4	211H6525
ø6.5 mm x 27.5 mm Vertebral Body Assembly	6	211H6527
ø6.5 mm x 30 mm Vertebral Body Assembly	6	211H6530
ø6.5 mm x 32.5 mm Vertebral Body Assembly	6	211H6532
ø6.5 mm x 35 mm Vertebral Body Assembly	6	211H6535
ø6.5 mm x 37.5 mm Vertebral Body Assembly	6	211H6537
ø6.5 mm x 40 mm Vertebral Body Assembly	6	211H6540
ø6.5 mm x 42.5 mm Vertebral Body Assembly	5	211H6542
ø6.5 mm x 45 mm Vertebral Body Assembly	4	211H6545
ø6.5 mm x 47.5 mm Vertebral Body Assembly	4	211H6547
ø6.5 mm x 50 mm Vertebral Body Assembly	2	211H6550
ø7.0 mm x 20 mm Vertebral Body Assembly	2	211H7020
ø7.0 mm x 22.5 mm Vertebral Body Assembly	2	211H7022
ø7.0 mm x 25 mm Vertebral Body Assembly	2	211H7025
ø7.0 mm x 27.5 mm Vertebral Body Assembly	2	211H7027
ø7.0 mm x 30 mm Vertebral Body Assembly	2	211H7030
ø7.0 mm x 32.5 mm Vertebral Body Assembly	2	211H7032
ø7.0 mm x 35 mm Vertebral Body Assembly	2	211H7035
ø7.0 mm x 37.5 mm Vertebral Body Assembly	2	211H7037
ø7.0 mm x 40 mm Vertebral Body Assembly	2	211H7040
ø7.0 mm x 42.5 mm Vertebral Body Assembly	2	211H7042
ø7.0 mm x 45 mm Vertebral Body Assembly	2	211H7045
ø7.0 mm x 47.5 mm Vertebral Body Assembly	2	211H7047
ø7.0 mm x 50 mm Vertebral Body Assembly	1	211H7050

### Implant Kit 5 - Vertebral Body Bone Screws Kit Number: PCR200H3105

The Vertebral Body Assembly includes a Bone Screw and a Set Screw. All implants are sterile packaged.

DESCRIPTION	QTY	PART NUMBER
300 mm Flexible PET Cord	2	204H0300
ø7.0 mm x 20 mm Vertebral Body Assembly	1	211H7020
ø7.0 mm x 22.5 mm Vertebral Body Assembly	2	211H7022
ø7.0 mm x 25 mm Vertebral Body Assembly	4	211H7025
ø7.0 mm x 27.5 mm Vertebral Body Assembly	6	211H7027
ø7.0 mm x 30 mm Vertebral Body Assembly	6	211H7030
ø7.0 mm x 32.5 mm Vertebral Body Assembly	6	211H7032
ø7.0 mm x 35 mm Vertebral Body Assembly	6	211H7035
ø7.0 mm x 37.5 mm Vertebral Body Assembly	6	211H7037
ø7.0 mm x 40 mm Vertebral Body Assembly	6	211H7040
ø7.0 mm x 42.5 mm Vertebral Body Assembly	4	211H7042
ø7.0 mm x 45 mm Vertebral Body Assembly	4	211H7045
ø7.0 mm x 47.5 mm Vertebral Body Assembly	4	211H7047
ø7.0 mm x 50 mm Vertebral Body Assembly	2	211H7050

**Disclaimer:** This document is intended exclusively for physicians and is not intended for laypersons. Information on the products and procedures contained in this document is of a general nature and does not represent and does not constitute medical advice or recommendations. Because this information does not purport to constitute any diagnostic or therapeutic statement with regard to any individual medical case, each patient must be examined and advised individually, and this document does not replace the need for such examination and/or advice in whole or in part.

**Caution:** Federal (USA) law restricts this device to sale by or on the order of a physician. Rx only. Please refer to the package inserts for important product information, including, but not limited to, indications, contraindications, warnings, precautions, adverse effects, and patient counseling information.

**eLabeling:** The Instructions for Use can be accessed online by visiting the website and using the KEY-CODE provided on the product label and as shown below. Additional languages are also available in electronic format for download. To request a paper copy of the Instructions for Use, contact Zimmer Biomet Spine at the phone number provided.



Consult Instructions for Use on this website <http://labeling.zimmerbiomet.com>  
Key-Code: IFU0021-0117



**Manufactured by:**

Zimmer Biomet Spine, Inc.  
10225 Westmoor Dr.  
Westminster, CO 80021 USA  
+1 800.447.3625



**ZIMMER BIOMET**  
Your progress. Our promise.®

800.447.3625/[zimmerbiomet.com](http://zimmerbiomet.com)

©2021 Zimmer Biomet Spine, Inc. All rights reserved.

All content herein is protected by copyright, trademarks and other intellectual property rights, as applicable, owned by or licensed to Zimmer Biomet Spine, Inc. or its affiliates unless otherwise indicated, and must not be redistributed, duplicated or disclosed, in whole or in part, without the express written consent of Zimmer Biomet Spine. This material is intended for health care professionals, the Zimmer Biomet Spine sales force and authorized representatives. Distribution to any other recipient is prohibited.

2302.3-US-en Issue Date 2021-02-28